



# The EQS

Effective from December 2024 Production.

Mercedes-Benz





Book a test drive



Find your EQS



Find a Showroom



Some of the model features, optional extras and colours shown may not be available, or may only be available in a different specification, or at a different price.

Design	Technology	Safety	Model lines	Model prices	Mercedes-AMG	Mercedes-AMG prices	Personalisation	Standard equipment	Genuine accessories	Technical data	Additional information
--------	------------	--------	-------------	--------------	--------------	---------------------	-----------------	--------------------	---------------------	----------------	------------------------



Book a test drive



Find your EQS



Find a Showroom



Some of the model features, optional extras and colours shown may not be available, or may only be available in a different specification, or at a different price.

Design	Technology	Safety	Model lines	Model prices	Mercedes-AMG	Mercedes-AMG prices	Personalisation	Standard equipment	Genuine accessories	Technical data	Additional information
--------	------------	--------	-------------	--------------	--------------	---------------------	-----------------	--------------------	---------------------	----------------	------------------------



Book a test drive



Find your EQS



Find a Showroom



Some of the model features, optional extras and colours shown may not be available, or may only be available in a different specification, or at a different price.

Design	Technology	Safety	Model lines	Model prices	Mercedes-AMG	Mercedes-AMG prices	Personalisation	Standard equipment	Genuine accessories	Technical data	Additional information
--------	------------	--------	-------------	--------------	--------------	---------------------	-----------------	--------------------	---------------------	----------------	------------------------



Some of the model features, optional extras and colours shown may not be available, or may only be available in a different specification, or at a different price.

<a href="#">Design</a>	<a href="#">Technology</a>	<a href="#">Safety</a>	<a href="#">Model lines</a>	<a href="#">Model prices</a>	<a href="#">Mercedes-AMG</a>	<a href="#">Mercedes-AMG prices</a>	<a href="#">Personalisation</a>	<a href="#">Standard equipment</a>	<a href="#">Genuine accessories</a>	<a href="#">Technical data</a>	<a href="#">Additional information</a>
------------------------	----------------------------	------------------------	-----------------------------	------------------------------	------------------------------	-------------------------------------	---------------------------------	------------------------------------	-------------------------------------	--------------------------------	--

[Book a test drive](#)[Find your EQS](#)[Find a Showroom](#)

Some of the model features, optional extras and colours shown may not be available, or may only be available in a different specification, or at a different price.

<a href="#">Design</a>	<a href="#">Technology</a>	<a href="#">Safety</a>	<a href="#">Model lines</a>	<a href="#">Model prices</a>	<a href="#">Mercedes-AMG</a>	<a href="#">Mercedes-AMG prices</a>	<a href="#">Personalisation</a>	<a href="#">Standard equipment</a>	<a href="#">Genuine accessories</a>	<a href="#">Technical data</a>	<a href="#">Additional information</a>
------------------------	----------------------------	------------------------	-----------------------------	------------------------------	------------------------------	-------------------------------------	---------------------------------	------------------------------------	-------------------------------------	--------------------------------	--



Book a test drive



Find your EQS



Find a Showroom



Some of the model features, optional extras and colours shown may not be available, or may only be available in a different specification, or at a different price.

Design	Technology	Safety	Model lines	Model prices	Mercedes-AMG	Mercedes-AMG prices	Personalisation	Standard equipment	Genuine accessories	Technical data	Additional information
--------	------------	--------	-------------	--------------	--------------	---------------------	-----------------	--------------------	---------------------	----------------	------------------------



Some of the model features, optional extras and colours shown may not be available, or may only be available in a different specification, or at a different price.

<a href="#">Design</a>	<a href="#">Technology</a>	<a href="#">Safety</a>	<a href="#">Model lines</a>	<a href="#">Model prices</a>	<a href="#">Mercedes-AMG</a>	<a href="#">Mercedes-AMG prices</a>	<a href="#">Personalisation</a>	<a href="#">Standard equipment</a>	<a href="#">Genuine accessories</a>	<a href="#">Technical data</a>	<a href="#">Additional information</a>
------------------------	----------------------------	------------------------	-----------------------------	------------------------------	------------------------------	-------------------------------------	---------------------------------	------------------------------------	-------------------------------------	--------------------------------	--





Book a test drive



Find your EQS



Find a Showroom



Some of the model features, optional extras and colours shown may not be available, or may only be available in a different specification, or at a different price.

Design	Technology	Safety	Model lines	Model prices	Mercedes-AMG	Mercedes-AMG prices	Personalisation	Standard equipment	Genuine accessories	Technical data	Additional information
--------	------------	--------	-------------	--------------	--------------	---------------------	-----------------	--------------------	---------------------	----------------	------------------------



Book a test drive



Find your EQS



Find a Showroom

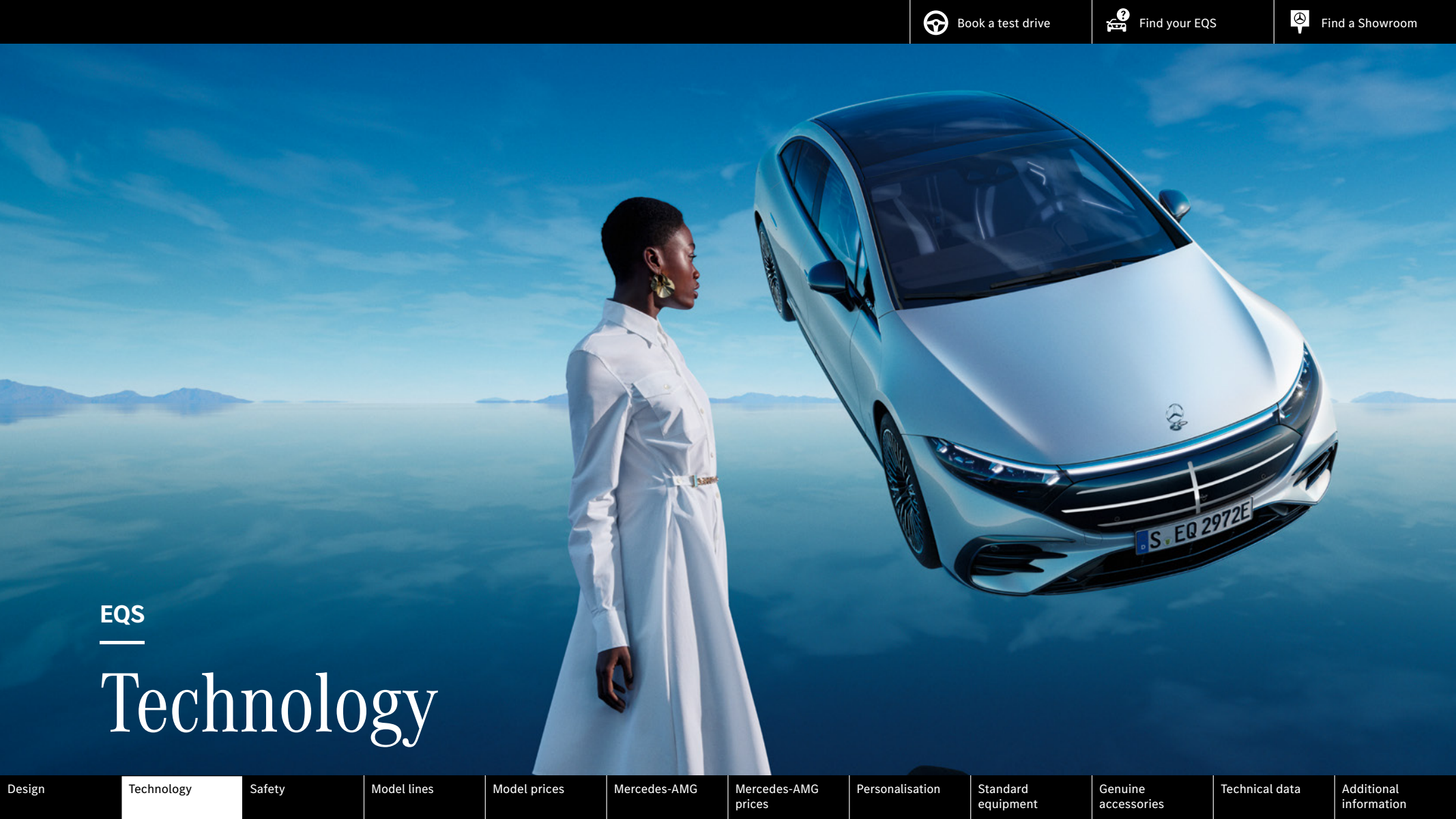

EQS

# Technology

Design

Technology

Safety

Model lines

Model prices

Mercedes-AMG

Mercedes-AMG prices

Personalisation

Standard equipment

Genuine accessories

Technical data

Additional information

# Digital Extras Stay connected any time, anywhere.

Digital Extras are a range of innovative online services designed to enhance your Mercedes-Benz experience. Accessible via mobile, tablet or PC, Digital Extras let you enjoy the highest standards of care and support, in a way that integrates seamlessly with your busy lifestyle.

### Safety and Service – Digital Extras help to keep you and your car safe

Check your car's washer fluid level, tyre pressure and battery level from your phone so you'll be ready for every journey.



### Live Traffic Information, Parked Vehicle Locator and much more

Forgot where you've parked? Parked Vehicle Locator<sup>1</sup> will show you exactly where your car is as long as you're in a 1-mile radius of where you parked. Real-time traffic data and dynamic route with shorter journey times.

For more information speak to your local Mercedes-Benz Agent or visit the Mercedes-Benz store at [shop.mercedes-benz.com/en-gb/connect](http://shop.mercedes-benz.com/en-gb/connect)

### Comfort – connect to your car anytime, anywhere

Forgot to lock your car? With Remote Car Lock<sup>2</sup> you will receive a notification on your smartphone to let you know. With one tap, you can lock and unlock your vehicle so you never have to worry.

### Specific services for all-electric vehicles from Mercedes-Benz

Check your charging status on the go and programme your pre-entry climate control and charging settings remotely. The specific navigation services for all-electric vehicles from Mercedes-Benz consider electrical range, topography and charging stations.



The connection of the communication module to the mobile phone network including the emergency call system depends on the respective network coverage and availability of network providers

<sup>1</sup>Available on all models with the Vehicle Monitoring package. This option may vary between standard and additional cost dependent on the model

<sup>2</sup>Part of the Vehicle Status package. This option may vary between standard and additional cost dependent on the model

Images shown are for illustration purposes only

Design	Technology	Safety	Model lines	Model prices	Mercedes-AMG	Mercedes-AMG prices	Personalisation	Standard equipment	Genuine accessories	Technical data	Additional information
--------	------------	--------	-------------	--------------	--------------	---------------------	-----------------	--------------------	---------------------	----------------	------------------------

# Mercedes-Benz Integrated ServiceCare

Effortless maintenance and peace of mind

Enjoy peace of mind with Mercedes-Benz Integrated ServiceCare, an exclusive service offering comprehensive support and maintenance, ensuring every aspect of your vehicle's upkeep, from brake fluid changes to dust filter replacements – all expertly handled.

With Integrated ServiceCare, you can enjoy worry-free maintenance coverage for up to 6 years or 90,000 km (56,250 miles), whichever comes first<sup>1</sup>. This comprehensive plan covers all maintenance operations<sup>2</sup>, including brake fluid change and dust filter replacement (Services A and B).

## Integrated ServiceCare

Standard on all models<sup>3</sup>

### Integrated ServiceCare includes:

**Maintenance services** – with a service schedule of A–B–A included, you can be reassured that all EQ-specific vehicle components are maintained, and your vehicle receives the appropriate level of care. Your preferred Mercedes-Benz Authorised Repairer will carry out either an 'A' or a more comprehensive 'B' service at the relevant mileage interval. This includes high-voltage battery conditioning checks as well as inspection of components, cables and sockets, and replacement of the dust filter. Parts, liquids and labour are all included.

**Additional work** – such as brake fluid replacement and servicing of panoramic sunroof mechanism. Parts, liquids and labour are all included.

### Please note that the following items are not covered by the Integrated ServiceCare:

Battery replacement for KEYLESS-GO vehicle key

Refilling or replacing the fragrance system's flacon (AIR-BALANCE package)



<sup>1</sup>The Integrated ServiceCare is fully transferrable to a new owner if there is coverage remaining

<sup>2</sup>Maintenance operations as defined by Mercedes-Benz AG

<sup>3</sup>All EQS Saloon models from MY805 onwards will come with Mercedes-Benz Integrated ServiceCare as standard



# Mercedes-Benz User Experience (MBUX)

Transforming the in-car user experience, thanks to MBUX: Controlled via voice, touch or optional gesture input, the innovative infotainment system can over time even predict personal habits thanks to artificial intelligence.

## Voice control

- Activated by the keywords “Hey Mercedes”, the new intelligent voice control LINGUATRONIC<sup>1</sup> lets you control many of the infotainment functions, including destination input, phone calls or music selection
- MBUX is able to understand different accents and will adjust to you over time
- MBUX even understands indirect commands. Feeling chilly? Just say “I feel cold” and MBUX will adjust the temperature for you

## Touch inputs

- Beside voice control you can operate MBUX via touchscreen, as well as touch control buttons on the steering wheel

## Personalisation

- Turn the EQS into your very own Mercedes-Benz by personalising driving modes, radio stations, ambient lighting and much more
- Your personal settings can be saved in up to seven different profiles, making your driving experience the best one possible
- Thanks to artificial intelligence, MBUX is able to learn and adapt over time. It will be able to predict your personal habits, such as navigation for frequently-driven routes, or the radio station you like to listen to on your way home from work

## Maintenance and service

- Wondering when the next service is due? Or how much further you can drive until you need to stop at a charging station? Just ask your MBUX - it will tell you the answer



The connection of the communication module to the mobile phone network including the emergency call system depends on the respective network coverage and availability of network providers

<sup>1</sup>LINGUATRONIC off-board functions are currently only available for three years

Design	Technology	Safety	Model lines	Model prices	Mercedes-AMG	Mercedes-AMG prices	Personalisation	Standard equipment	Genuine accessories	Technical data	Additional information
--------	------------	--------	-------------	--------------	--------------	---------------------	-----------------	--------------------	---------------------	----------------	------------------------



# MBUX Hyperscreen

Introducing the MBUX Hyperscreen – an evolution in display technology that transforms the user interface. Bringing together a 12.3-inch LCD driver display, a 17.7-inch OLED central display with haptic feedback, and an additional 12.3-inch OLED front passenger display under a seamless glass cover, the MBUX Hyperscreen sets a new standard for seamless connectivity and sophistication.

## Standard on all model lines

### Consisting of:

Driver display with 12.3-inch screen diagonal, LCD with LED matrix backlighting

OLED central display with 17.7-inch screen diagonal and haptic feedback

OLED front passenger display with 12.3-inch screen diagonal and haptic feedback

A continuous, seamless glass surface integrating all three displays



# EQS EQS 350 and EQS 450+

Vehement power immediately from standstill: An electric motor at the rear axle converts electrical into mechanical energy, and delivers impressive forward thrust. The intelligent operating strategy of the powertrain components supplies the power always wherever it is needed at the moment – efficiently and nearly silently.

## EQS 350

Battery electric vehicle, 292 hp/215 kW  
Electric range 378–409 miles – WLTP

## EQS 450+

Battery electric vehicle, 360 hp/265 kW  
Electric range 444–481 miles – WLTP



### Standard equipment

AIRMATIC air suspension	Charging system – rated at 200 kW DC (EQS 450+)
Charging cable for wallbox and public charging stations, type 2 (Mode 3) – 5 metres	Charging socket
Charging socket	Pre-entry climate control <sup>1</sup>
Charging system – rated at 11 kW AC	Radar-based recuperation
Charging system – rated at 170 kW DC (EQS 350)	

### Technical details

	EQS 350	EQS 450+
Electric range <sup>2</sup>	378–409 miles	444–481 miles
Charging time		
Public Rapid charger (170 kW DC) 10–80% <sup>3</sup>	32 mins	–
Public Rapid charger (200 kW DC) 10–80% <sup>3</sup>	–	31 mins
Wallbox (11 kW AC) 0–100% <sup>4</sup>	10 hrs 15 mins	12 hrs 15 mins
Home wallbox (7.4 kW AC) 0–100% <sup>4</sup>	15 hrs	18 hrs 30 mins
Energy consumption, combined <sup>3,5</sup>	172–186 Wh/km	175–191 Wh/km
Battery type (usable)	lithium-ion (96 kWh)	lithium-ion (118 kWh)
Capacity on-board charger	11 kW AC/170 kW DC	11 kW AC/200 kW DC

### Attention



Using the pre-entry climate control<sup>1</sup> when plugged into a charge point will ensure the perfect ambience and ensure that your car is just how you like it, as well as making sure that your battery isn't used unnecessarily to heat/cool the vehicle (maximising range).



Please be aware that external factors such as weather, gradient and ambient temperature amongst others can significantly impact range.  
Please also note that internal factors such as driving style and climate control settings etc. can also significantly impact range.

<sup>1</sup>The connection of the communication module to the mobile phone network including the emergency call system depends on the respective network coverage and availability of network providers. <sup>2</sup>Figures shown are for comparability purposes; only compare with other cars tested to the same technical procedures. Figures may not reflect real life driving results, which will depend upon a number of factors including the starting charge of the battery, factory-fitted options, accessories fitted (post registration), variations in weather, driving styles and vehicle load. Further information about the test used to establish range, power consumption and CO<sub>2</sub> figures can be found at <http://www.mercedes-benz.co.uk/WLTP>. <sup>3</sup>Specified voltage and current values refer to network infrastructure and can be limited by the vehicle. Times are from 10–80% charge using public rapid charging at 200 kW. <sup>4</sup>Specified voltage and current values refer to network infrastructure and can be limited by the vehicle. Times are from 0–100% charge using a wallbox (three-phase) or standard socket (single-phase). <sup>5</sup>Specified voltage and current values refer to network infrastructure and can be limited by the vehicle.

# EQS Mercedes-AMG EQS 53 4MATIC+

Vehement power immediately from standstill: An electric motor at the rear axle converts electrical into mechanical energy, and delivers impressive forward thrust. The intelligent operating strategy of the powertrain components supplies the power always wherever it is needed at the moment – efficiently and nearly silently.



**Mercedes-AMG EQS 53 4MATIC+**  
 Battery electric vehicle, 658 hp/484 kW  
 Electric range 339–378 miles – WLTP

### Standard equipment

AIRMATIC air suspension	Charging system – rated at 200 kW DC
Charging cable for wallbox and public charging stations, type 2 (Mode 3) – 5 metres	Charging socket
Charging socket	Pre-entry climate control <sup>1</sup>
Charging system – rated at 22 kW AC	Radar-based recuperation

### Technical details

Electric range <sup>2</sup>	339–378 miles
Charging time	
Public Rapid charger (200 kW DC) 10–80% <sup>3</sup>	31 mins
Wallbox (22 kW AC) 0–100% <sup>4</sup>	6 hrs 15 mins
Home wallbox (7.4 kW AC) 0–100% <sup>4</sup>	18 hrs 30 mins
Energy consumption, combined <sup>3,5</sup>	216–238 Wh/km
Battery type (usable)	lithium-ion (118 kWh)
Capacity on-board charger	22 kW AC/200 kW DC



### Attention

Please be aware that external factors such as weather, gradient and ambient temperature amongst others can significantly impact range.

Please also note that internal factors such as driving style and climate control settings etc. can also significantly impact range.

Using the pre-entry climate control<sup>1</sup> when plugged into a charge point will ensure the perfect ambience and ensure that your car is just how you like it, as well as making sure that your battery isn't used unnecessarily to heat/cool the vehicle (maximising range).

<sup>1</sup>The connection of the communication module to the mobile phone network including the emergency call system depends on the respective network coverage and availability of network providers. Number of factors including the starting charge of the battery, factory-fitted options, accessories fitted (post registration), variations in weather, driving styles and vehicle load. Further information about the test used to establish range, power consumption and CO<sub>2</sub> figures can be found at <http://www.mercedes-benz.co.uk/WLTP> and can be limited by the vehicle. Times are from 10–80% charge using public rapid charging at 200 kW and can be limited by the vehicle.

<sup>2</sup>Figures shown are for comparability purposes; only compare with other cars tested to the same technical procedures. Figures may not reflect real life driving results, which will depend upon a number of factors including the starting charge of the battery, factory-fitted options, accessories fitted (post registration), variations in weather, driving styles and vehicle load. Further information about the test used to establish range, power consumption and CO<sub>2</sub> figures can be found at <http://www.mercedes-benz.co.uk/WLTP>

<sup>3</sup>Specified voltage and current values refer to network infrastructure and can be limited by the vehicle. Times are from 0–100% charge using a wallbox (three-phase) or standard socket (single-phase)

<sup>5</sup>Specified voltage and current values refer to network infrastructure and can be limited by the vehicle.



# MB.CHARGE Public<sup>1</sup> Features

MB.CHARGE Public<sup>1</sup> provides access to a multitude of public charging stations located in shopping centres, hotels or at motorway services. A smartphone app as well as the vehicle's navigation system show the precise location, current availability and price at the selected charging station.

## Tens of thousands charging stations in the UK

Growing network of charging providers includes bp pulse the largest charging network in the UK.

## Charging with IONITY

IONITY unlimited – free rapid charging for one year at all IONITY stations.<sup>2</sup>



## Access to fast-charging stations

Enables customers to get access to charging stations of different providers with:

- Mercedes-Benz app
- RFID card
- Vehicle Head unit

## Green charging

All charging using MB.CHARGE Public<sup>1</sup> will be retrospectively 'greened' by Mercedes-Benz. Please click [here](#) for more info.

## Transparent and easy billing

One invoice charging processes for payment.

## Easy access

Charging stations are displayed in Mercedes-Benz app and in MBUX multimedia system.

## No fees

MB.CHARGE Public<sup>1</sup> is standard with EQS.

## Charging settings and pre-entry climate control<sup>1</sup>

Enjoy your feel-good temperature when you enter your vehicle. You can simply preheat or precool the interior by setting the temperature via the Mercedes-Benz app. In addition, the current charge status can be retrieved at any time using the Mercedes-Benz app.

## Navigation with Electric Intelligence

Offering you the greatest possible planning security on the road. Many items of information, such as a fast and convenient route, current state of battery charge, weather data and charging infrastructure, are interlinked. A convenient and time-efficient route is then suggested to you, including charging stops if necessary.



<sup>1</sup>The connection of the communication module to the mobile phone network including the emergency call system depends on the respective network coverage and availability of network providers registered owner of the vehicle only and expires at the end of a period of one year from the activation of the service and cannot be transferred to third parties your cancellation rights and current pricing can be found <https://eu.charge.mercedes-benz.com/web/en/mb-gb/tariffs>

<sup>2</sup>With the IONITY unlimited service, charging costs are only included for EQS customers for one year from activation of the service. Please note that this exclusive offer is applicable to the first Price information is not guaranteed and is subject to change. Please be aware that this tariff will automatically renew after the 1 year promotion period - for definitive pricing information or should you not wish to continue with the tariff,

# MB.CHARGE Public<sup>1</sup> Tariffs

For more transparency and predictability, enjoy numerous features tailored to your charging habits with the MB.CHARGE Public<sup>1</sup> fixed-priced tariffs S, M and L. Owners of a new all-electric model from Mercedes-Benz will be entitled to the MB.CHARGE Public<sup>1</sup> tariff L free of charge for the duration of 12 months.

## Tariff L

Recommended for 'frequent drivers'

Owners of a new all-electric model are entitled to the tariff L free of charge for 12 months, benefitting from fixed prices, discounted rapid-charging at IONITY charging stations<sup>2</sup> and complete transparency. This tariff is recommended for frequent and long-distance drivers.

Consisting of:

- All MB.CHARGE Public<sup>1</sup> features
- Fixed prices per kWh (AC: £0.45/kWh, after 300 mins +£0.06/min; DC: £0.62/kWh)<sup>3</sup>
- IONITY rapid-charging stations discounted (£0.53/kWh)<sup>2</sup>

**Free of charge for the duration of 12 months.**

**Thereafter:**

**£10.90/month**

## Tariff M

Recommended for 'regular drivers'

Should you wish to downgrade your tariff package after 12 months but still want to benefit from fixed prices, discounted rapid-charging at IONITY charging stations<sup>2</sup> and complete transparency, choose tariff M. This tariff is recommended for regular drivers.

Consisting of:

- All MB.CHARGE Public<sup>1</sup> features
- Fixed prices per kWh (AC: £0.52/kWh, after 300 mins +£0.06/min; DC: £0.69/kWh)<sup>3</sup>
- IONITY rapid-charging stations discounted (£0.60/kWh)<sup>2</sup>

**£4.90/month**

## Tariff S

Recommended for 'casual drivers'

Should you wish to downgrade your tariff package after 12 months, there is the option to go for tariff S, which still offers you all the MB.CHARGE Public<sup>1</sup> features based on flexible prices per kWh. This tariff is recommended for casual drivers.

Consisting of:

- All MB.CHARGE Public<sup>1</sup> features
- Flexible prices per kWh

**£0/month**



<sup>1</sup>The connection of the communication module to the mobile phone network including the emergency call system depends on the respective network coverage and availability of network providers. <sup>2</sup>With the IONITY unlimited service, charging costs are only included for EQS customers for one year from activation of the service. Please note that this exclusive offer is applicable to the first registered owner of the vehicle only and expires at the end of a period of one year from the activation of the service and cannot be transferred to third parties. <sup>3</sup>Tariff rate excludes the BP Pulse charging network. Price information is not guaranteed and is subject to change. Please be aware that this tariff will automatically renew after the 1 year promotion period - for definitive pricing information or should you not wish to continue with the tariff, your cancellation rights and current pricing can be found <https://eu.charge.mercedes-benz.com/web/en/mb-gb/tariffs>

# Next generation of home EV charging with Ohme

Mercedes-Benz plug-in vehicle customers with off-street parking can benefit from the convenience and speed of charging at home by installing an Ohme charger.

## Home charging with Ohme: from £925\* incl. VAT and standard installation

### Key benefits of Ohme:

Ohme specialise in providing future-proof electric vehicle charging solutions, in particular smart, affordable and easy-to-use charging products.

Save money: If you have a time-of-use tariff or a variable tariff, you'll pay less for your electricity at certain times of the day. Ohme uses your tariff information to charge your vehicle when the price is low to maximise your savings.

Ohme is the only EV charging provider to integrate with all energy tariffs, including Intelligent Octopus and OVO Charge Anytime – the next generation, smart EV charging tariffs.

Easy installation process.

Choice of tethered or untethered units.

Award-winning customer service – check Trustpilot for more information.

A 3-year warranty is included.

Connect your charger to the Ohme smartphone app to unlock smarter and cheaper charging at home. Easy-to-use, the Ohme app will give you full control to get more from your EV.

Ohme's chargers are compliant with the UK New Smart Charger Regulations for complete peace of mind.

### OZEV Grant:

You may be entitled to claim for an OZEV grant towards the cost of your home charger!<sup>1</sup> To find out whether you are entitled please contact your local Mercedes-Benz Agent.

### Questions?

Please contact your local Mercedes-Benz Agent to submit an enquiry to your chosen charging partner on your behalf. To find your local Mercedes-Benz Agent, please click the button at the top right hand corner.

### Warning!

If you are planning to charge your Mercedes-Benz plug-in electric vehicle using a 3-pin domestic plug socket you must get a qualified electrician to inspect and sign off the socket to confirm it is safe and suitable to charge your vehicle. Do not use an electric vehicle 3-pin charge cable with an extension cord.



\*Price excludes £350 OZEV EVHS Grant. Price correct at time of publication, subject to change  
<sup>1</sup>The home charger £350 Grant (including VAT) is only available to customers who meet the criteria of the Office for Zero Emission Vehicles (OZEV). For full details and eligibility criteria for the OZEV EVHS Grant, see <https://www.gov.uk/government/publications/electric-vehicle-homecharge-scheme-guidance-for-customers-version-21>.

# Home charging with Pod Point Simple, convenient, fast charging.



Mercedes-Benz plug-in vehicle customers with off-street parking can benefit from the convenience and speed of charging at home by installing a Pod Point home charger.

## Home charging with Pod Point: from £925\* incl. VAT and standard installation

For full terms and conditions please visit <https://pod-point.com/legal/home-charger-terms-of-sale>

### Key benefits of Pod Point:

Pod Point is one of the leading provider of EV charging in the UK with over 250,000 home chargepoints installed.

Auto Power Balancing lets you adjust your charge so that your electrical supply doesn't get overloaded when your home is using a lot of energy.

Built-in earthing protection removes the needs for expensive earth rods.

Choice of tethered or untethered units; £925 for a 7 kW universal, and £975 for 7 kW tethered.

The Pod Point public network consists of over 9,200 charging bays across the UK.

5 year warranty as standard, free of charge.

The standard installation package includes up to 15m of external cabling.

Utilise charge scheduling in conjunction with an off-peak EV tariff to reduce your charging costs by up to 70% compared with the current Energy Price Cap.<sup>1</sup>

### OZEV Grant:

You may be entitled to claim for an OZEV grant towards the cost of your home charger.<sup>2</sup>

To find out whether you are entitled please contact your local Mercedes-Benz Agent.

### Questions?

Please contact your local Mercedes-Benz Agent to submit an enquiry to your chosen charging partner on your behalf. To find your local Mercedes-Benz Agent, please click the button at the top right hand corner.

### Warning!

If you are planning to charge your Mercedes-Benz plug-in electric vehicle using a 3-pin domestic plug socket you must get a qualified electrician to inspect and sign off the socket to confirm it is safe and suitable to charge your vehicle. Do not use an electric vehicle 3-pin charge cable with an extension cord.



<sup>1</sup>Price excludes £350 OZEV EVHS Grant. Price correct at time of publication, subject to change <sup>2</sup>Based on an off-peak tariff of 8 p/kWh compared with the energy price cap until 31 March 2025 of 24.86 p/kWh <sup>3</sup>The home charger £350 Grant (including VAT) is only available to customers who meet the criteria of the Office for Zero Emission Vehicles (OZEV). For full details and eligibility criteria for the OZEV EVHS Grant, see <https://www.gov.uk/government/publications/electric-vehicle-homecharge-scheme-guidance-for-customers-version-21>.



Book a test drive



Find your EQS



Find a Showroom

EQS

# Safety



Design	Technology	Safety	Model lines	Model prices	Mercedes-AMG	Mercedes-AMG prices	Personalisation	Standard equipment	Genuine accessories	Technical data	Additional information
--------	------------	--------	-------------	--------------	--------------	---------------------	-----------------	--------------------	---------------------	----------------	------------------------

[Book a test drive](#)[Find your EQS](#)[Find a Showroom](#)

# DIGITAL LIGHT

 High-definition headlamps with innovative features

The new innovative DIGITAL LIGHT headlamps works like a projector with more than one million pixels per headlamp and responds with brilliant light to changing traffic, road or weather conditions. Its ULTRA RANGE Highbeam with 650 m makes you feel like driving at daylight.

**Standard on all model lines**



<a href="#">Design</a>	<a href="#">Technology</a>	<a href="#">Safety</a>	<a href="#">Model lines</a>	<a href="#">Model prices</a>	<a href="#">Mercedes-AMG</a>	<a href="#">Mercedes-AMG prices</a>	<a href="#">Personalisation</a>	<a href="#">Standard equipment</a>	<a href="#">Genuine accessories</a>	<a href="#">Technical data</a>	<a href="#">Additional information</a>
------------------------	----------------------------	------------------------	-----------------------------	------------------------------	------------------------------	-------------------------------------	---------------------------------	------------------------------------	-------------------------------------	--------------------------------	--



Book a test drive



Find your EQS



Find a Showroom

# Driving Assistance package Plus Cares for what matters.

The EQS comes with standard ground-breaking innovations in safety, comfort and driving functions, to help you stay safe on the road.

## Standard on all model lines



Active Lane Keeping Assist

**Active Blind Spot Assist** expanded with blind spot monitoring towards the front and side. Additional hazard indication of the blind spot warning system as well as exit warning function

**Active Brake Assist with cross-traffic function** with turning manoeuvre function (responding to (among other things) crossing pedestrians when making a turn). Operating range on urban routes expanded to 74 mph (previously 44 mph)

**Active Distance Assist DISTRONIC** responds to stationary road users to prevent collisions up to 80 mph (previously 37 mph)

**Active Emergency Stop Assist** is able to assist in manual mode (previously on in DISTRONIC mode). Optional lane change by one lane (at 49 mph where no obstacles detected)

**Active Evasive Steering Assist** responds to cyclists and ends of tailbacks in addition to pedestrians. Operating range on urban routes expanded to 67 mph (previously 44 mph)

**Active Lane Keeping Assist** with enhanced comfort thanks to active steering intervention (instead of braking intervention) and additional hazard indication

**Active Speed Limit Assist** ensures detected speed limits are automatically adopted as the set speed for Active Distance Assist DISTRONIC

**Active Traffic Sign Assist**

**Congestion emergency braking function**

**Emergency corridor function**

**Exit warning function when hand moves towards the door handles**

**Extended automatic restart on motorways**

**Hazard display via ambient lighting**

Increased availability and cornering performance on carriageways with **Active Steering Assist**, more stern warnings to put hands on the steering wheel with new capacitive steering wheel

**PRE-SAFE® PLUS and Impulse Side with body-raising function:** when a rear-end collision threatens, PRE-SAFE® PLUS can initiate preventive measures, including warning following traffic and locking the brakes on standstill

**Route-based speed adjustment with end of traffic jam function and Active Stop-and-Go Assist** adaption of speed before curves, roundabouts and junctions with end of traffic jam function



Active Distance Assist DISTRONIC

\*Our driver assistance and safety systems are aids and do not relieve you of your responsibility as the driver. Please take note of the information in the Owner's Manual and the system limits which are described therein

Design	Technology	Safety	Model lines	Model prices	Mercedes-AMG	Mercedes-AMG prices	Personalisation	Standard equipment	Genuine accessories	Technical data	Additional information
--------	------------	--------	-------------	--------------	--------------	---------------------	-----------------	--------------------	---------------------	----------------	------------------------



Book a test drive



Find your EQS



Find a Showroom

# EQS Model lines overview



**AMG Line Premium »**



**AMG Line Premium Plus »**



**Business Class »**

Design	Technology	Safety	Model lines	Model prices	Mercedes-AMG	Mercedes-AMG prices	Personalisation	Standard equipment	Genuine accessories	Technical data	Additional information
--------	------------	--------	-------------	--------------	--------------	---------------------	-----------------	--------------------	---------------------	----------------	------------------------



# EQS AMG Line Premium



Option shown: high-tech silver metallic (code 922)

## Unleash the epitome of performance and luxury.

Experience the dynamic charm of the EQS AMG Line Premium with its 21" AMG multi-spoke alloy wheels, AMG Exterior styling and the panoramic sliding sunroof. Experience the cutting-edge MBUX Hyperscreen at your fingertips, and enjoy the pleasure of driving in the comfort of AMG sports seats and a heated AMG multifunction steering wheel,

while the journey unfolds in unparalleled audio delight courtesy of the Burmester® 3D surround sound system, providing an immersive audio experience.

**EQS AMG Line Premium**

**OTR from £99,785<sup>1</sup>**

<sup>1</sup>The recommended on-the-road price includes the Road Fund Licence applicable to the standard model plus delivery charge (£730.00 incl.VAT), new vehicle registration fee (£55.00) and number plates (£25.00 incl.VAT). VAT is calculated at the standard rate of 20%. Some of the model features, optional extras and colours shown may not be available, or may only be available in a different specification, or at a different price

Design	Technology	Safety	Model lines	Model prices	Mercedes-AMG	Mercedes-AMG prices	Personalisation	Standard equipment	Genuine accessories	Technical data	Additional information
--------	------------	--------	-------------	--------------	--------------	---------------------	-----------------	--------------------	---------------------	----------------	------------------------

# EQS AMG Line Premium Standard equipment highlights



Option shown: high-tech silver metallic (code 922)



Option shown: high-tech silver metallic (code 922)

## Exterior

21" AMG alloy wheels – multi-spoke design, aerodynamically optimised, painted black with a high-sheen finish (code RWX)

Acoustic privacy glass

AMG Exterior styling

Headlamps – DIGITAL LIGHT with light band

Heat pump

KEYLESS-GO

Mirror package

Panoramic sliding sunroof

Radiator grille with luxury panel and standing star

Soft closing doors



DIGITAL LIGHT with light band





**Communications, Safety and Assistance Systems**

5G communications module <sup>1</sup>	MBUX Hyperscreen
Burmester® 3D surround sound system	Parking package – Active Park Assist <sup>2</sup> and 360° camera
Driving Assistance package Plus <sup>2</sup>	Wireless charging system <sup>3</sup> for mobile devices (front and rear)
GUARD 360° vehicle protection Plus <sup>2</sup>	
MBUX augmented reality for navigation	

**Servicing**

Mercedes-Benz Integrated ServiceCare – the maintenance service covers all necessary maintenance work for 6 years or 90,000 km (56,250 miles)<sup>4</sup>

Burmester® 3D surround sound system and MBUX Hyperscreen



**Interior**

Active ambient lighting	AMG sports seats in leather upholstery
Air Quality package	Electrically adjustable rear seats
AMG brushed stainless steel sports pedals with black rubber studs	Heated front and rear seats
AMG door sills, illuminated, with 'AMG' lettering	Heated steering wheel
AMG floor mats	Heated windscreen
AMG multifunction sports steering wheel in nappa leather	Memory package
	THERMOTRONIC automatic climate control

**Trim and Upholstery**

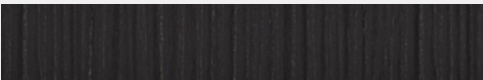
Leather – black/space grey	Anthracite linestructure lime wood
	

<sup>1</sup>The connection of the communication module to the mobile phone network including the emergency call system depends on the respective network coverage and availability of network providers as described therein <sup>2</sup>Compatible smartphone required. For further details please visit <https://www.mercedes-benz-mobile.com/>

<sup>3</sup>The driver assistance and safety systems are aids and do not relieve you of your responsibility as the driver. Please take note of the information in the Owner's Manual and the system limits which are described therein <sup>4</sup>The Integrated ServiceCare is fully transferrable to a new owner if there is coverage remaining. All EQS Saloon models from MY805 onwards will come with Mercedes-Benz Integrated ServiceCare as standard

# EQS AMG Line Premium Plus



Option shown: nautic blue metallic (code 595)

## Elevate your EQS to the next level with smart features.

With the AMG Line Premium Plus you can benefit from advanced parking capabilities thanks to the Parking package, complete with a 360° camera and remote parking functionality. Stay informed and focused with the head-up display, ensuring essential

information is effortlessly within your line of sight. The integrated dashcam adds a new dimension to capturing moments on the road.

**EQS AMG Line Premium Plus**  
**Upgrade price from EQS AMG Line Premium**

**OTR from £106,785<sup>1</sup>**  
**£7,000**

<sup>1</sup>The recommended on-the-road price includes the Road Fund Licence applicable to the standard model plus delivery charge (£730.00 incl. VAT), new vehicle registration fee (£55.00) and number plates (£25.00 incl. VAT). VAT is calculated at the standard rate of 20%. Some of the model features, optional extras and colours shown may not be available, or may only be available in a different specification, or at a different price

Design	Technology	Safety	Model lines	Model prices	Mercedes-AMG	Mercedes-AMG prices	Personalisation	Standard equipment	Genuine accessories	Technical data	Additional information
--------	------------	--------	-------------	--------------	--------------	---------------------	-----------------	--------------------	---------------------	----------------	------------------------

# EQS AMG Line Premium Plus Standard equipment highlights



Option shown: nautic blue metallic (code 595)



Option shown: nautic blue metallic (code 595)

In addition to/replacement of AMG Line Premium:

### Exterior

21" alloy wheels – multi-spoke design, aerodynamically optimised, painted high-gloss black with a high-shine finish (code RWY)

Summer tyres



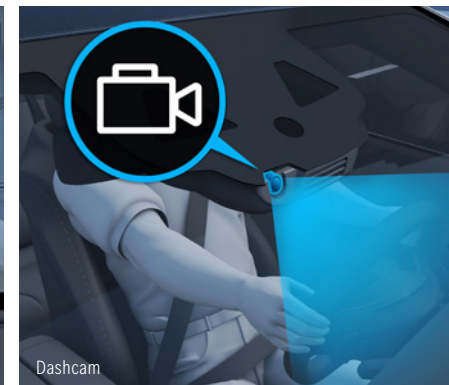

**Communications, Safety and Assistance Systems**

Dashcam

Head-up display

MBUX Interior Assistant (front)

Parking package – Active Park Assist<sup>1</sup>, 360° camera and remote parking including a three-year subscription to Remote Parking<sup>2</sup>

**Trim and Upholstery**

Leather – black/space grey

Anthracite linestructure lime wood

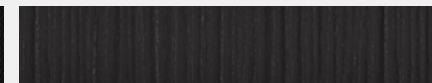
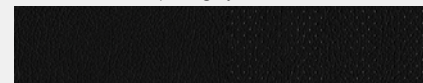

<sup>1</sup>Our driver assistance and safety systems are aids and do not relieve you of your responsibility as the driver. Please take note of the information in the Owner's Manual and the system limits which are described therein of network providers

<sup>2</sup>The connection of the communication module to the mobile phone network including the emergency call system depends on the respective network coverage and availability

Design	Technology	Safety	Model lines	Model prices	Mercedes-AMG	Mercedes-AMG prices	Personalisation	Standard equipment	Genuine accessories	Technical data	Additional information
--------	------------	--------	-------------	--------------	--------------	---------------------	-----------------	--------------------	---------------------	----------------	------------------------

# EQS Business Class



Standard paint colour shown: obsidian black metallic (code 197)

## Luxury redefined: explore elevated comfort in the EQS Business Class

Step into unparalleled comfort and sophistication with the EQS Business Class. Indulge in luxury with front head restraints and multi-contour seats featuring a massage function, seamlessly blending advanced technology with opulent design for an unparalleled journey.

**EQS Business Class**  
**Upgrade price from EQS AMG Line Premium**

**OTR from £106,785<sup>1</sup>**  
**£7,000**

<sup>1</sup>The recommended on-the-road price includes the Road Fund Licence applicable to the standard model plus delivery charge (£730.00 incl. VAT), new vehicle registration fee (£55.00) and number plates (£25.00 incl. VAT). VAT is calculated at the standard rate of 20%. Some of the model features, optional extras and colours shown may not be available, or may only be available in a different specification, or at a different price

Design	Technology	Safety	Model lines	Model prices	Mercedes-AMG	Mercedes-AMG prices	Personalisation	Standard equipment	Genuine accessories	Technical data	Additional information
--------	------------	--------	-------------	--------------	--------------	---------------------	-----------------	--------------------	---------------------	----------------	------------------------

# EQS Business Class Standard equipment highlights



Standard paint colour shown: obsidian black metallic (code 197)



Standard paint colour shown: obsidian black metallic (code 197)

In addition to/replacement of AMG Line Premium Plus:

#### Exterior

22" alloy wheels – 5-twin-spoke design, aerodynamically optimised, painted black with a high-sheen finish (code 00R)

Summer tyres







### Interior

Luxury front head restraints

Velour floor mats in black

Multi-contour seats with energising massage function

### Trim and Upholstery

Nappa leather - black/space grey

Ship's deck open-pore walnut wood trim

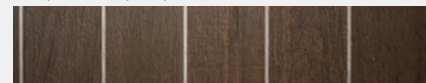

[Book a test drive](#)[Find your EQS](#)[Find a Showroom](#)

# Model prices

VED and BIK applicable for registrations up to 31 March 2025

Model line	Powertrain	CO <sub>2</sub> WLTP <sup>1,*</sup>	Basic RRP excl. VAT (£)	Total RRP incl. VAT (£)	Road Fund Licence (£) <sup>2</sup> WLTP	Rec. OTR price (£) <sup>3</sup> WLTP	P11D value (£)	BIK tax rate 2024/25 (%) <sup>2</sup>
<b>AMG Line Premium</b>								
EQS 350	Battery electric vehicle, 292hp/215 kW Electric range up to 409 miles - WLTP <sup>1</sup>	0	82,479.17	98,975.00	0.00	<b>99,785.00</b>	99,730.00	2
EQS 450+	Battery electric vehicle, 360 hp/265 kW Electric range up to 481 miles - WLTP <sup>1</sup>	0	93,125.00	111,750.00	0.00	<b>112,560.00</b>	112,505.00	2
<b>AMG Line Premium Plus</b>								
EQS 350	Battery electric vehicle, 292hp/215 kW Electric range up to 406 miles - WLTP <sup>1</sup>	0	88,312.50	105,975.00	0.00	<b>106,785.00</b>	106,730.00	2
EQS 450+	Battery electric vehicle, 360 hp/265 kW Electric range up to 479 miles - WLTP <sup>1</sup>	0	98,958.33	118,750.00	0.00	<b>119,560.00</b>	119,505.00	2
<b>Business Class</b>								
EQS 350	Battery electric vehicle, 292hp/215 kW Electric range up to 379 miles - WLTP <sup>1</sup>	0	88,312.50	105,975.00	0.00	<b>106,785.00</b>	106,730.00	2
EQS 450+	Battery electric vehicle, 360 hp/265 kW Electric range up to 446 miles - WLTP <sup>1</sup>	0	98,958.33	118,750.00	0.00	<b>119,560.00</b>	119,505.00	2

<sup>1</sup>The indicated values were determined according to the prescribed measurement method - Worldwide Harmonised Light Vehicle Test Procedure (WLTP). Figures shown may include options which are not available in the UK. Battery Electric Vehicles (BEV) require mains electricity for charging, range figures determined with the battery fully charged. <sup>2</sup>Figures shown are for comparability purposes; only compare with other cars tested to the same technical procedures. Figures may not reflect real life driving results, which will depend upon a number of factors including the starting charge of the battery, factory-fitted options, accessories fitted (post registration), variations in weather, driving styles and vehicle load. Further information about the test used to establish range, power consumption and CO<sub>2</sub> figures can be found at <http://www.mercedes-benz.co.uk/WLTP> <sup>3</sup>A different first year rate of Vehicle Excise Duty (Road Fund Licence) applies for new cars. Please refer to page 68 for the relevant rate for the second and subsequent years <sup>4</sup>The recommended on-the-road price includes the Road Fund Licence applicable to the standard model plus delivery charge (£730.00 incl. VAT), new vehicle registration fee (£55.00) and number plates (£25.00 incl. VAT). VAT is calculated at the standard rate of 20%. Some of the model features, optional extras and colours shown may not be available, or may only be available in a different specification, or at a different price



Book a test drive



Find your EQS



Find a Showroom



AMG



EQS

# Mercedes-AMG

Design

Technology

Safety

Model lines

Model prices

Mercedes-AMG

Mercedes-AMG prices

Personalisation

Standard equipment

Genuine accessories

Technical data

Additional information

# Mercedes-AMG EQS Model lines overview



**Mercedes-AMG EQS 53 4MATIC+ Night Edition »**



**Mercedes-AMG EQS 53 4MATIC+ Touring »**



# Mercedes-AMG EQS 53 4MATIC+ Night Edition



Option shown: MANUFAKTUR opalite white metallic (code 885)

## Electric mobility meets AMG heritage.

The Mercedes-AMG EQS 53 4MATIC+ Night Edition carries all the traditional AMG values into electric mobility. This model features 21" AMG alloy wheels with red-painted brake callipers, AMG front and rear bumpers, AMG spoiler lip on the boot lid and a panoramic sunroof. The AMG styling continues inside with AMG sports seats in nappa leather with climatised front seats, heated AMG Performance steering wheel as well as AMG

brushed stainless steel sports pedals with black rubber studs. The MBUX Hyperscreen and Burmester® 3D surround sound system form part of the standard equipment.

## Mercedes-AMG EQS 53 4MATIC+ Night Edition

**OTR from £161,810<sup>1</sup>**

<sup>1</sup>The recommended on-the-road price includes the Road Fund Licence applicable to the standard model plus delivery charge (£730.00 incl. VAT), new vehicle registration fee (£55.00) and number plates (£25.00 incl. VAT). VAT is calculated at the standard rate of 20%. Some of the model features, optional extras and colours shown may not be available, or may only be available in a different specification, or at a different price

Design	Technology	Safety	Model lines	Model prices	Mercedes-AMG	Mercedes-AMG prices	Personalisation	Standard equipment	Genuine accessories	Technical data	Additional information
--------	------------	--------	-------------	--------------	--------------	---------------------	-----------------	--------------------	---------------------	----------------	------------------------

# Mercedes-AMG EQS 53 4MATIC+ Night Edition Standard equipment highlights



Option shown: MANUFAKTUR opalite white metallic (code 885)



Option shown: MANUFAKTUR opalite white metallic (code 885)

## Exterior

21" AMG alloy wheels – cross-spoke design, aerodynamically optimised, painted matt black and rim flange with a high-sheen finish (code RWW)

Acoustic privacy glass

AMG front bumper painted in vehicle colour with A-wing in high-gloss black and trim in chrome, front splitter in high-gloss chrome with flics and fins at the left and right air inlets in high-gloss black with chrome trim

AMG rear apron painted in vehicle colour with diffuser-look inserts in high-gloss black, double trim strip in chrome and flics at the left and right air outlets in grained black

AMG spoiler lip on the boot lid

Brake callipers in red paint

Heat pump

KEYLESS-GO

Panoramic roof

Side skirts painted in high-gloss black with insert in chrome

Soft closing doors

Steering – 9° rear axle steering

Summer tyres



Design	Technology	Safety	Model lines	Model prices	Mercedes-AMG	Mercedes-AMG prices	Personalisation	Standard equipment	Genuine accessories	Technical data	Additional information
--------	------------	--------	-------------	--------------	--------------	---------------------	-----------------	--------------------	---------------------	----------------	------------------------



**Communications, Safety and Assistance Systems**

- 5G communications module<sup>1</sup>
- Burmester® 3D surround sound system
- Dashcam
- MBUX augmented navigation
- MBUX Hyperscreen
- Wireless charging system<sup>2</sup> for mobile devices in the rear



**Servicing**

Mercedes-Benz Integrated ServiceCare – the maintenance service covers all necessary maintenance work for 6 years or 90,000 km (56,250 miles)<sup>3</sup>

**Interior**

- |  |  |
|--|--|
| <ul style="list-style-type: none"> <li>Air Quality package</li> <li>AMG brushed stainless steel sports pedals with black rubber studs</li> <li>AMG Performance steering wheel in nappa leather/ microfibre MICROCUT</li> <li>AMG sports seats in nappa leather</li> <li>Climatised front seats</li> <li>Comfort armrest in the rear</li> </ul> | <ul style="list-style-type: none"> <li>Dashboard and beltlines in space grey ARTICO man-made leather with NEOTEX grain and red topstitching</li> <li>Electrically adjustable rear seats</li> <li>Heated rear seats</li> <li>Heated steering wheel</li> <li>Heated windscreen</li> <li>Luxury head rests in the rear</li> </ul> |
|--|--|



Heated steering wheel



9° rear axle steering

**Trim and Upholstery**

AMG nappa leather – black/space grey

Anthracite linestructure lime wood trim

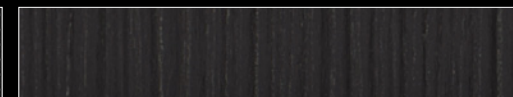

<sup>1</sup>The connection of the communication module to the mobile phone network including the emergency call system depends on the respective network coverage and availability of network providers with Mercedes-Benz Integrated ServiceCare as standard

<sup>2</sup>Compatible mobile phone required

<sup>3</sup>The Integrated ServiceCare is fully transferrable to a new owner if there is coverage remaining. All EQS Saloon models from MY805 onwards will come

Design	Technology	Safety	Model lines	Model prices	Mercedes-AMG	Mercedes-AMG prices	Personalisation	Standard equipment	Genuine accessories	Technical data	Additional information
--------	------------	--------	-------------	--------------	--------------	---------------------	-----------------	--------------------	---------------------	----------------	------------------------



# Mercedes-AMG EQS 53 4MATIC+ Touring



Option shown: graphite grey metallic (code 831)

## Electric mobility meets AMG heritage.

The Mercedes-AMG EQS 53 4MATIC+ Touring carries all the traditional AMG values into electric mobility. This model features 22" AMG alloy wheels with silver-painted brake callipers. Inside, you're greeted by the AMG Performance steering wheel in nappa leather, AMG sports seats in AMG nappa leather, matched with the ship's deck maple wood trim.

**Mercedes-AMG EQS 53 4MATIC+ Touring**

**OTR from £161,810<sup>1</sup>**

<sup>1</sup>The recommended on-the-road price includes the Road Fund Licence applicable to the standard model plus delivery charge (£730.00 incl. VAT), new vehicle registration fee (£55.00) and number plates (£25.00 incl. VAT). VAT is calculated at the standard rate of 20%. Some of the model features, optional extras and colours shown may not be available, or may only be available in a different specification, or at a different price

Design	Technology	Safety	Model lines	Model prices	Mercedes-AMG	Mercedes-AMG prices	Personalisation	Standard equipment	Genuine accessories	Technical data	Additional information
--------	------------	--------	-------------	--------------	--------------	---------------------	-----------------	--------------------	---------------------	----------------	------------------------



# Mercedes-AMG EQS 53 4MATIC+ Touring Standard equipment highlights



Option shown: graphite grey metallic (code 831)



Option shown: graphite grey metallic (code 831)

In addition to/replacement of Mercedes-AMG EQS 53 4MATIC+ Night Edition:

### Exterior

22" AMG alloy wheels - multi-spoke design, aerodynamically optimised, painted matt black and rim flange with a high-shine finish (code RPD)

Silver callipers

Summer tyres



Design	Technology	Safety	Model lines	Model prices	Mercedes-AMG	Mercedes-AMG prices	Personalisation	Standard equipment	Genuine accessories	Technical data	Additional information
--------	------------	--------	-------------	--------------	--------------	---------------------	-----------------	--------------------	---------------------	----------------	------------------------



#### Interior

AMG Performance steering wheel in nappa leather

AMG sports seats in nappa leather

#### Trim and Upholstery

AMG nappa leather - black/space grey



Ship's deck open-pore walnut wood

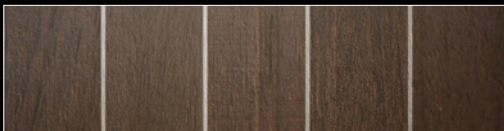



Book a test drive



Find your EQS



Find a Showroom

# Become the AMG expert

Unleash a new level of performance.



Step into the world of performance and experience the AMG brand at Mercedes-Benz World – from the powerful sound of the engines to the smell of the leather to the unmistakable design of our vehicles.

Mercedes-Benz World invites all Mercedes-AMG customers to a complimentary adrenaline-packed driving experience. Feel the sensational AMG driving performance, develop your driving skills and even try your hand at power-sliding on the Wet Skid Circle. With expert one-to-one guidance from a Driving Specialist in the passenger seat, experience every inch of our Handling Circuits, Dynamic Straight and low friction surfaces.

[Click here for more information](#)



#### TERMS AND CONDITIONS

The following customers only are eligible: The first purchaser/registered keeper of a newly registered Mercedes-AMG. The complimentary training must be booked and taken within 12 months of email receipt. The training is available Monday - Friday only (excluding bank holidays) and subject to availability. Upgrades are available for an additional cost, details upon request. Transferable to individuals who reside at the same postal address only. Mercedes-Benz UK Limited reserves the right to amend or withdraw this training experience. Attendees must hold a full UK driving licence. Attendees will be required to sign the Mercedes-Benz World Driving Risk Acknowledgement prior to undertaking the training experience.

The training experience is also subject to the Mercedes-Benz World Terms and Conditions, as applicable. Retailer demonstrator vehicles are not eligible.

Design	Technology	Safety	Model lines	Model prices	Mercedes-AMG	Mercedes-AMG prices	Personalisation	Standard equipment	Genuine accessories	Technical data	Additional information
--------	------------	--------	-------------	--------------	--------------	---------------------	-----------------	--------------------	---------------------	----------------	------------------------

# Mercedes-AMG prices



VED and BIK applicable for registrations up to 31 March 2025

Model line	Powertrain	CO <sub>2</sub> WLTP <sup>1</sup> *	Basic RRP excl. VAT (£)	Total RRP incl. VAT (£)	Road Fund Licence (£) <sup>2</sup> WLTP	Rec. OTR price (£) <sup>3</sup> WLTP	P11D value (£)	BIK tax rate 2024/25 (%) <sup>2</sup>
Mercedes-AMG EQS 53 4MATIC+ Night Edition	Battery electric vehicle, 658 hp/484 kW Electric range up to 378 miles – WLTP <sup>1</sup>	0	134,166.67	161,000.00	0.00	<b>161,810.00</b>	161,755.00	2
Mercedes-AMG EQS 53 4MATIC+ Touring	Battery electric vehicle, 658 hp/484 kW Electric range up to 341 miles – WLTP <sup>1</sup>	0	134,166.67	161,000.00	0.00	<b>161,810.00</b>	161,755.00	2

<sup>1</sup>The indicated values were determined according to the prescribed measurement method - Worldwide Harmonised Light Vehicle Test Procedure (WLTP). Figures shown may include options which are not available in the UK. Battery Electric Vehicles (BEV) require mains electricity for charging, range figures determined with the battery fully charged. <sup>2</sup>Figures shown are for comparability purposes; only compare with other cars tested to the same technical procedures. Figures may not reflect real life driving results, which will depend upon a number of factors including the starting charge of the battery, factory-fitted options, accessories fitted (post registration), variations in weather, driving styles and vehicle load. Further information about the test used to establish range, power consumption and CO<sub>2</sub> figures can be found at <http://www.mercedes-benz.co.uk/WLTP> <sup>3</sup>A different first year rate of Vehicle Excise Duty (Road Fund Licence) applies for new cars. Please refer to page 68 for the relevant rate for the second and subsequent years <sup>3</sup>The recommended on-the-road price includes the Road Fund Licence applicable to the standard model plus delivery charge (£730.00 incl. VAT), new vehicle registration fee (£55.00) and number plates (£25.00 incl. VAT). VAT is calculated at the standard rate of 20%. Some of the model features, optional extras and colours shown may not be available, or may only be available in a different specification, or at a different price

Design	Technology	Safety	Model lines	Model prices	Mercedes-AMG	Mercedes-AMG prices	Personalisation	Standard equipment	Genuine accessories	Technical data	Additional information
--------	------------	--------	-------------	--------------	--------------	---------------------	-----------------	--------------------	---------------------	----------------	------------------------



Book a test drive



Find your EQS



Find a Showroom

# Personalisation Overview



Paints »



Upholstery »



Packages »

Design	Technology	Safety	Model lines	Model prices	Mercedes-AMG	Mercedes-AMG prices	Personalisation	Standard equipment	Genuine accessories	Technical data	Additional information
--------	------------	--------	-------------	--------------	--------------	---------------------	-----------------	--------------------	---------------------	----------------	------------------------

# Colour options

Standard  No-cost option

Total prices incl. VAT



197 obsidian black metallic



831 graphite grey metallic



818 MANUFAKTUR graphite grey magno £6,300.00



346 onyx black metallic



842 sodalite blue metallic



885 MANUFAKTUR opalite white metallic £725.00



595 nautic blue metallic



922 high-tech silver metallic



993 MANUFAKTUR patagonia red metallic £725.00

Please note that, owing to limitations of on-screen representation, paint colours may differ from those shown

Design	Technology	Safety	Model lines	Model prices	Mercedes-AMG	Mercedes-AMG prices	Personalisation	Standard equipment	Genuine accessories	Technical data	Additional information
--------	------------	--------	-------------	--------------	--------------	---------------------	-----------------	--------------------	---------------------	----------------	------------------------

# Upholstery

● Standard   □ No-cost option   – Not available



**231A Leather<sup>1</sup> – black/space grey**

AMG Line Premium	●
AMG Line Premium Plus	●
Business Class	–



**229A Leather<sup>1</sup> – neva grey/balao brown**

AMG Line Premium	□
AMG Line Premium Plus	□
Business Class	–



**801A Nappa leather<sup>2</sup> – black/space grey**

AMG Line Premium	–
AMG Line Premium Plus	–
Business Class	●

<sup>1</sup>At least 80% of the seat upholstery is pure leather, while up to 20% may consist of man-made leather

<sup>2</sup>100% of seat upholstery is pure leather

Please note that, owing to limitations of on-screen representation, upholstery colours may differ from those shown

# Upholstery

No-cost option     Not available



**805A Nappa leather<sup>1</sup> - macchiato beige/space grey**

AMG Line Premium	–
AMG Line Premium Plus	–
Business Class	<input type="checkbox"/>



**811A Nappa leather<sup>1</sup> - black/balao brown**

AMG Line Premium	–
AMG Line Premium Plus	–
Business Class	<input type="checkbox"/>



**821A Nappa leather<sup>1</sup> - black/biscay blue**

AMG Line Premium	–
AMG Line Premium Plus	–
Business Class	<input type="checkbox"/>

<sup>1</sup>100% of seat upholstery is pure leather    Please note that, owing to limitations of on-screen representation, upholstery colours may differ from those shown



# Upholstery Mercedes-AMG

● Standard   □ No-cost option



**851A AMG nappa leather<sup>1</sup> – black/space grey**

Night Edition interior with sports seats shown

- Mercedes-AMG EQS 53 4MATIC+ Night Edition
- Mercedes-AMG EQS 53 4MATIC+ Touring



**859A AMG nappa leather<sup>1</sup> – neva grey/balao brown**

Night Edition interior with sports seats shown

- Mercedes-AMG EQS 53 4MATIC+ Night Edition
- Mercedes-AMG EQS 53 4MATIC+ Touring



**861A AMG nappa leather<sup>1</sup> – black/balao brown**

Night Edition interior with sports seats shown

- Mercedes-AMG EQS 53 4MATIC+ Night Edition
- Mercedes-AMG EQS 53 4MATIC+ Touring

<sup>1</sup>100% of seat upholstery is pure leather   Please note that, owing to limitations of on-screen representation, upholstery colours may differ from those shown



# Rear Luxury Lounge package

Optimum seating comfort in the rear: control your ideal seating position and enjoy a range of massage programmes achieved with the multi-contour seats – all of which is controlled by the MBUX tablet in the rear armrest.

**Rear Luxury Lounge package (code DR1)** – designed and priced as a package.

**Business Class<sup>1</sup> and Mercedes-AMG EQS 53 4MATIC+ Touring**

**Total incl. VAT £3,000.00**

### Consisting of:

Beltbag

Electrically-adjustable rear seats

Climatised rear seats

MBUX Interior Assist in the rear

Comfort armrest in the rear

MBUX rear tablet



<sup>1</sup>Only available with upholstery 801A, 805A, 811A and 821A



# Extended Rear Luxury Lounge package

Introducing the Extended Rear Luxury Lounge package, boasting the same features as the Rear Luxury Lounge package and additional enhancements for an even more luxurious experience.

**Extended Rear Luxury Lounge package (code DR2)<sup>1</sup>** – designed and priced as a package.

**Business Class and Mercedes-AMG EQS 53 4MATIC+ Touring**

**Total incl. VAT £6,500.00**

## Consisting of:

Climatised rear seats	MBUX Interior Assist in the rear
Comfort armrests in the rear	MBUX rear tablet
Electrically-adjustable rear seats	Multicontour rear seats
Executive seats with an electrically adjustable backrest angle of up to 38° degrees and luxury head cushions	Neck and shoulder heating in the rear
Exclusive nappa leather black/Exclusive AMG nappa leather black	Seat heating Plus outer rear seat
	Seat on front passenger side electrically adjustable
	Two rear cushions



<sup>1</sup>This package only comes with the Exclusive nappa leather/Exclusive AMG nappa leather in black. Not available in conjunction with upholstery codes 801A, 805A, 811A and 821A



# MBUX High-End Rear Seat Entertainment System

Introducing MBUX High-End Rear Seat Entertainment System with two 11.6-inch displays, wireless headphones, and access to vehicle functions while driving. Enjoy multimedia options like TV streaming and web browsing. Experience seamless entertainment in the rear even while driving.

**MBUX High-End Rear Seat Entertainment System (code 854)<sup>1</sup>** – designed and priced as a package.

**Business Class and Mercedes-AMG EQS 53 4MATIC+ Touring**

**Total incl. VAT £3,000.00**

## Consisting of:

Access to vehicle functions while driving:

- MBUX multimedia system – TV streaming via internet/radio/media/web browser/ Mercedes-Benz apps
- Digital Extras<sup>2</sup>
- Telephone
- Travel information, among others navigation display

Two permanently integrated, high-resolution 11.6-inch displays:

- Multi-touch operation
- Sound output from vehicle speakers or headphones

Two wireless headphones

Various connection options:

- Bluetooth Audio
- Headphone jack (3.5 mm)
- Mini HDMI

Mirroring of display content including remote control, additionally with selection of MBUX rear tablet



<sup>1</sup>Only in conjunction with Rear Luxury Lounge package (code DR1) or Extended Rear Luxury Lounge package (code DR2)

<sup>2</sup>The connection of the communication module to the mobile phone network including the emergency call system depends on the respective network coverage and availability of network providers

Design	Technology	Safety	Model lines	Model prices	Mercedes-AMG	Mercedes-AMG prices	Personalisation	Standard equipment	Genuine accessories	Technical data	Additional information
--------	------------	--------	-------------	--------------	--------------	---------------------	-----------------	--------------------	---------------------	----------------	------------------------

# AMG Performance package

Exclusively designed for the Mercedes-AMG EQS 53 4MATIC+ Night Edition, the AMG Performance package is an attractive optional extra for the power-hungry sports driver looking for the ultimate AMG experience.

**AMG Performance package (code DPP)** – designed and priced as a package.

**Available on Mercedes-AMG EQS 53 4MATIC+ Night Edition only**

**Total incl. VAT £8,995.00**

## Consisting of:

AMG carbon-fibre trim

AMG Driver's package for a maximum top speed increased to 155 mph

AMG DYNAMIC PLUS package – boost for RACE START by briefly increasing maximum power and torque

AMG high-performance ceramic composite braking system

AMG sound experience performance, in three versions 'Balanced', 'Sport' and 'Powerful' for drive sounds

AMG TRACK PACE

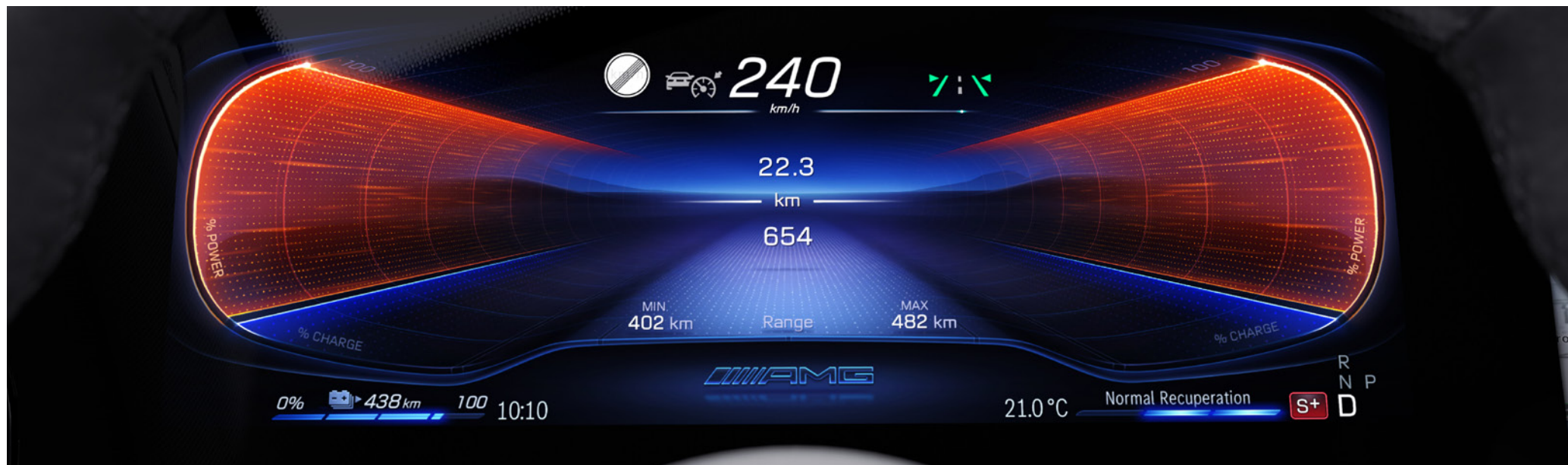



# Standard equipment

● Standard – Not available

## Battery and Charging

	AMG Line Premium	AMG Line Premium Plus	Business Class
11kW AC on-board charger	●	●	●
96 kWh battery (EQS 350)	●	●	●
118 kWh battery (EQS 450+)	●	●	●
170 kW DC on-board charger (EQS 350)	●	●	●
200 kW DC on-board charger (EQS 450+)	●	●	●
CCS-2 connector (DC charging with Combined Charging System, compatible with AC and DC)	●	●	●
Charging cable – Mode 3 cable (5 metres), Type 2, enables you to charge the vehicle battery via the wallbox or at public charging stations	●	●	●
MB.CHARGE Public <sup>1</sup> – fully integrated access to a host of public charging stations. A single contract covers all billing. One-time registration and activation as part of Digital Extras <sup>1</sup> . Use via app, MBUX multimedia system or RFID card	●	●	●
Heat pump	●	●	●
IONITY unlimited – free rapid charging for one year at all IONITY stations <sup>2</sup>	●	●	●

## Transmission and Suspension

AIRMATIC air suspension struts with integrated adaptive damping system at the front and rear axle – automatic level control system, depending on load: load detection for a constant suspension level. Suspension level can be raised for rough roads and is automatically lowered at high speeds, MBUX can remember these actions and suggest them when arriving at the same location	●	●	●
DYNAMIC SELECT – three different drive programs, ECO, COMFORT and SPORT with the ability to save an INDIVIDUAL program, five recuperation levels: D Auto (ECO Assist, standard setting), D + (coasting), D (low recuperation), D - (medium recuperation), D - - (high recuperation)	●	●	●

## Exterior

	AMG Line Premium	AMG Line Premium Plus	Business Class
Acoustic privacy glass – dark tinted rear and rear side windows with noise reduction and optimised heat protection	●	●	●
AMG Exterior styling	●	●	●
AMG front bumper painted in vehicle colour with A-wing in high-gloss black and trim in chrome, front splitter in high-gloss chrome with flics and fins at the left and right air inlets in high-gloss black with chrome trim	●	●	●
AMG rear apron painted in vehicle colour with diffuser-look inserts in high-gloss black, double trim strip in chrome and flics at the left and right air outlets in grained black	●	●	●
AMG side skirts painted in high-gloss black with insert in chrome	●	●	●
Headlamps – DIGITAL LIGHT	●	●	●
Heat-insulating, noise-insulating and infrared-reflecting laminated glass	●	●	●
Heated windscreen washer system	●	●	●
KEYLESS-GO	●	●	●
Mirror package – electrically folding exterior mirrors, automatically dimming interior and exterior driver mirror, surround lighting in both outside mirrors with brand logo projection to illuminate the entrance area	●	●	●
Panoramic sliding sunroof	●	●	●
Radiator grille with luxury panel and standing star	●	●	●
Soft closing doors	●	●	●

<sup>1</sup>The connection of the communication module to the mobile phone network including the emergency call system depends on the respective network coverage and availability of network providers registered owner of the vehicle only and expires at the end of a period of one year from the activation of the service and cannot be transferred to third parties

<sup>2</sup>With the IONITY unlimited service, charging costs are only included for EQS customers for one year from activation of the service. Please note that this exclusive offer is applicable to the first



# Standard equipment

● Standard – Not available

## Wheels

	AMG Line Premium	AMG Line Premium Plus	Business Class
21" AMG alloy wheels – multi-spoke design, aerodynamically optimised, painted black with a high-sheen finish, 265/40 R21 tyres (code RWX)	●	–	–
21" alloy wheels – multi-spoke design, aerodynamically optimised, painted high-gloss black with a high-sheen finish, 265/40 R21 tyres (code RWY)	–	●	–
22" alloy wheels – 5-twin-spoke design, aerodynamically optimised, painted black with a high-sheen finish, 265/35 R22 tyres (code 00R)	–	–	●
Summer tyres	●	●	●

## Interior

Air Quality package – infrared quality sensor plus a fine particle sensor on outside and inside. Includes coarse, HEPA fine particle and broad spectrum filter against fine particles (PM2.5), pollen, nitrogen dioxides (NOx), sulphur dioxides (SO2) and certain viruses. Antibacterial effect reduces the growth of fungi and bacteria on the interior air filter. Automatic switching between air recirculation or fresh air depending on the measured air quality. Air quality menu in the MBUX multimedia system	●	●	●
AMG Interior Design package – AMG sports steering wheel, AMG pedals, AMG door sills with 'AMG' illuminated lettering and AMG velour floor mats	●	●	–
Black velour floor mats	–	–	●
Comfort armrest in the rear	●	●	●
Lighting – active ambient lighting in 64 static colours, all colours can be selected individually. High-quality matt-white line as part of the lamellar trim with 190 integrated and individually controllable LEDs. Diverse colour moods, also with static or multicolour animated colour worlds. Driving assistance system interaction, parking and manoeuvring functions. Outline of electric driving: drive, recuperation, boost. Emotively appealing animations: welcome display or feedback in colour when adjusting the air conditioning or interaction with the voice control. Incorporation of active ambient lighting into the programmes of ENERGIZING comfort control and variable setting of the brightness for automatic day and night switchover	●	●	●

AMG Line Premium  
AMG Line Premium Plus  
Business Class

Lighting – Interior Light package	●	●	●
Memory package – electrical adjustment and memory function for front seats, steering wheel, outside mirror, heated areas of the seat cushion and seat backrest, head-up display (where fitted), four-way front lumbar support and seat cushion length. Includes PRE-SAFE® positioning function for front passenger seat	●	●	●
Seats – climatized (front)	–	–	●
Seats – electrically adjustable seats (rear)	●	●	●
Seats – heated (rear)	●	●	●
Seats – luxury head restraints (front)	–	–	●
Seats – luxury head rests (rear)	●	●	●
Seats – multi-contour seats with ENERGIZING massage function	–	–	●
Seats – split-fold rear seats	●	●	●
Storage compartment under centre console	●	●	●
THERMOTRONIC automatic climate control	●	●	●
Windscreen – heated	●	●	●

## Steering

Steering – 10° rear axle steering	●	●	●
Steering wheel – AMG multifunction sports steering wheel in nappa leather	●	●	●
Steering wheel – heated	●	●	●

[Book a test drive](#)[Find your EQS](#)[Find a Showroom](#)

# Standard equipment

● Standard    – Not available

## Paint, Trim and Upholstery

	AMG Line Premium	AMG Line Premium Plus	Business Class
Dashboard in leather look	●	●	–
Paint – metallic	●	●	●
Trim – centre console and door panels in anthracite linestructure lime wood	●	●	–
Trim – centre console and door panels in ship's deck open-pore walnut wood	–	–	●
Roof lining – black fabric	●	●	●
Upholstery – leather	●	●	–
Upholstery – nappa leather	–	–	●

## Safety and Assistance Systems

	AMG Line Premium	AMG Line Premium Plus	Business Class
Active Traffic Sign Assist <sup>1</sup>	●	●	●
Dashcam	–	●	●
Driving Assistance package Plus <sup>1</sup>	●	●	●
EASY-PACK tailgate	●	●	●
GUARD 360° vehicle protection Plus <sup>2</sup> – anti-theft protection hardware including alarm and immobilizer. Theft notification and park damage detection <sup>3</sup> , stolen vehicle locator <sup>3</sup> , 360° surroundview-camera snapshots <sup>3</sup> and remote key immobilizer <sup>3</sup>	●	●	●
KEYLESS-GO Comfort package	●	●	●
Mercedes-Benz emergency call system <sup>2,4</sup>	●	●	●
Parking package – Active Park Assist <sup>1</sup> and 360° camera	●	–	–
Parking package – Active Park Assist <sup>1</sup> , 360° camera and remote parking including a three-year subscription to Remote Parking <sup>2</sup>	–	●	●
Tirefit	●	●	●

## Communications and In-Car Entertainment

	AMG Line Premium	AMG Line Premium Plus	Business Class
5G communications module <sup>2</sup>	●	●	●
Digital radio	●	●	●
EQ navigation services <sup>2</sup> – navigation optimised for Mercedes-Benz EQ, range on map (range display), display of charging stations (info on availability, programming of charging settings and pre-entry climate control <sup>2</sup> including remote retrieval of charging status and range	●	●	●
Fingerprint scanner – colour-illuminated fingerprint scanner in the trim strip below the OLED media display, two fingerprints per user can be stored, quick access replaces PIN entry, protects personal data such as profiles plus office and payment functions	●	●	●
Hard-disc navigation	●	●	●
Head-up display	–	●	●
Live traffic information <sup>2</sup> – 3 years	●	●	●
MBUX augmented reality for navigation	●	●	●
MBUX Hyperscreen	●	●	●
MBUX Interior Assistant (front)	–	●	●
Pre-entry climate control <sup>1</sup>	●	●	●
Pre-installation for Car Sharing <sup>1</sup>	●	●	●
Smartphone integration <sup>5</sup>	●	●	●
Sound system – Burmester® 3D surround sound system	●	●	●
USB package – six fast charging USB-C ports including four compatible for data transfer	●	●	●
Wireless charging system <sup>5</sup> for mobile devices (front and rear)	●	●	●

<sup>1</sup>Our driver assistance and safety systems are aids and do not relieve you of your responsibility as the driver. Please take note of the information in the Owner's Manual and the system limits which are described therein

<sup>2</sup>The connection of the communication module to the mobile phone network including the emergency call system depends on the respective network coverage and availability of network providers

<sup>3</sup>Free of charge for three years from activation

<sup>4</sup>Free of charge for three years from activation

<sup>5</sup>Please be aware Mercedes-Benz emergency call system comes as standard for the first 10 years of the vehicle's lifecycle

<sup>6</sup>Compatible smartphone required. For further details please visit <https://www.mercedes-benz-mobile.com/>





# Standard equipment

● Standard    – Not available

## Services

	AMG Line Premium	AMG Line Premium Plus	Business Class
Geofencing <sup>1</sup> – available to use free of charge for three years following activation <sup>2</sup> , denotes a specific area and notifies via push message when the vehicle leaves or enters this area	●	●	●
Mercedes-Benz Integrated ServiceCare – the maintenance service covers all necessary maintenance work for 6 years or 90,000 km (56,250 miles) <sup>3</sup>	●	●	●
Parked vehicle locator <sup>1</sup> – available to use free of charge for three years following activation <sup>2</sup> , shows the position of the parked vehicle in a radius of approx. 1.5 km	●	●	●
Personalisation <sup>1</sup> – available to use free of charge for three years following activation <sup>2</sup> , stores settings such as the radio station or navigation destination in the personal driver profile and enables these to be used in vehicles with the same telematics generation, the profile can be linked to the key, and the functions can therefore already be activated before getting in	●	●	●
Programming of auxiliary heater/ventilation <sup>1</sup>	●	●	●
Remote door locking and unlocking <sup>1</sup> – available to use free of charge for three years following activation <sup>2</sup> , provides convenient remote monitoring	●	●	●
Remote retrieval of vehicle status <sup>1,2</sup> – shows mileage, tyre pressure, washer fluid level, etc.	●	●	●
Remote vehicle finder <sup>1</sup> – available to use free of charge for three years following activation <sup>2</sup> indicators activated via the app help to draw attention to the vehicle, for example in large, confusing car parks	●	●	●

	AMG Line Premium	AMG Line Premium Plus	Business Class
Sliding sunroof/windows with remote closing and opening including ventilation function <sup>2</sup> to use free of charge for three years following activation <sup>2</sup> for a breath of fresh air in the vehicle available	●	●	●
Send2Car function <sup>1</sup> – available to use free of charge for three years following activation <sup>2</sup> , sends selected addresses via the app to the vehicle's navigation system, for example POIs or restaurants	●	●	●
Speedfencing <sup>1</sup>	●	●	●
Stolen Vehicle Help <sup>1</sup> (free of charge for 3 years from activation) – this service reduces the bureaucratic effort required and gives you an advantage in terms of time. In the event of theft, you can report it to the police. You can transfer the police file number (depending on country) plus the relevant vehicle and owner information quite simply via app to our certified partner's security centre. This centre will then coordinate with the local police station to track your vehicle	●	●	●
Valet protect <sup>1</sup> – available to use free of charge for 3 years following activation <sup>2</sup> notifies via the app when the ignition is switched on/off and when the vehicle moves outside a defined radius (1 km, 2.5 km or 5 km)	●	●	●
Vehicle Tracking <sup>1</sup>	●	●	●

<sup>1</sup>The connection of the communication module to the mobile phone network including the emergency call system depends on the respective network coverage and availability of network providers. Upon expiry of the initial term, the services can be extended for a fee. Initial activation of the services is possible within 1 year of first registration or commissioning by the customer, whichever occurs first. ServiceCare as standard

<sup>2</sup>To use this service, you must register on the Mercedes-Benz portal and also accept the Terms of Use for the Digital Extras. In addition, the respective vehicle must be paired with the user account.

<sup>3</sup>The Integrated ServiceCare is fully transferrable to a new owner if there is coverage remaining. All EQS Saloon models from MY805 onwards will come with Mercedes-Benz Integrated ServiceCare as standard

[Book a test drive](#)[Find your EQS](#)[Find a Showroom](#)

# Mercedes-AMG Standard equipment

● Standard    – Not available

## Battery and Charging

	EQS-53 4MATIC+ Night Edition	EQS-53 4MATIC+ Touring
22 kW AC on-board charger	●	●
118 kWh battery	●	●
200 kW DC on-board charger	●	●
CCS-2 connector (DC charging with Combined Charging System, compatible with AC and DC)	●	●
Charging cable – Mode 3 cable (5 metres), Type 2, enables you to charge the vehicle battery via the wallbox or at public charging stations	●	●
Heat pump	●	●
IONITY unlimited – free rapid charging for one year at all IONITY stations <sup>1</sup>	●	●
MB.CHARGE Public <sup>2</sup> – fully integrated access to a host of public charging stations. A single contract covers all billing. One-time registration and activation as part of Digital Extras <sup>2</sup> . Use via app, MBUX multimedia system or RFID card	●	●

## Transmission and Suspension

AIRMATIC air suspension struts with integrated adaptive damping system at the front and rear axle – automatic level control system, depending on load: load detection for a constant suspension level. Suspension level can be raised for rough roads and is automatically lowered at high speeds, MBUX can remember these actions and suggest them when arriving at the same location	●	●
DYNAMIC SELECT – three different drive programs, ECO, COMFORT and SPORT with the ability to save an INDIVIDUAL program, five recuperation levels: D Auto (ECO Assist, standard setting), D + (coasting), D (low recuperation), D - (medium recuperation), D - - (high recuperation)	●	●

## Exterior

	EQS-53 4MATIC+ Night Edition	EQS-53 4MATIC+ Touring
Acoustic privacy glass – dark tinted rear and rear side windows with noise reduction and optimised heat protection	●	●
AMG Exterior styling	●	●
AMG-specific radiator grille with integrated Mercedes-Benz star	●	●
Brake callipers – red	●	–
Brake callipers – silver	–	●
Headlamps – DIGITAL LIGHT	●	●
Heat-insulating, noise-insulating and infrared-reflecting laminated glass	●	●
Heated windscreen washer system	●	●
KEYLESS-GO	●	●
Mirror package – electrically folding exterior mirrors, automatically dimming interior and exterior driver mirror, surround lighting in both outside mirrors with brand logo projection to illuminate the entrance area	●	●
Panoramic sliding sunroof	●	●
Soft closing doors	●	●

## Wheels

21" AMG alloy wheels – cross-spoke design, aerodynamically optimised, painted matt black and rim flange with a high-sheen finish, 275/40 R21 tyres (code RWW)	●	–
22" AMG alloy wheels – multi-spoke design, aerodynamically optimised, painted matt black and rim flange with a high-sheen finish, 275/35 R22 tyres (code RPD)	–	●
Summer tyres	●	●

<sup>1</sup>With the IONITY unlimited service, charging costs are only included for EQS customers for one year from activation of the service. Please note that this exclusive offer is applicable to the first registered owner of the vehicle only and expires at the end of a period of one year from the activation of the service and cannot be transferred to third parties

<sup>2</sup>The connection of the communication module to the mobile phone network including the emergency call system depends on the respective network coverage and availability of network providers

[Book a test drive](#)[Find your EQS](#)[Find a Showroom](#)

# Mercedes-AMG Standard equipment

● Standard    – Not available

## Interior

	EQS53 4MATIC+ Night Edition	EQS53 4MATIC+ Touring
Air Quality package – infrared quality sensor plus a fine particle sensor on outside and inside includes Course, HEPA fine particle and Broad spectrum filter against fine particles (PM2.5), pollen, nitrogen dioxides (NOx), sulphur dioxides (SO2) and certain viruses. Antibacterial effect reduces the growth of fungi and bacteria on the interior air filter. Automatic switching between air recirculation or fresh air depending on the measured air quality. Air quality menu in the MBUX multimedia system	●	●
AMG Interior Design package – AMG sports steering wheel, AMG pedals, AMG door sills with 'AMG' illuminated lettering and AMG velour floor mats	●	●
Black velour floor mats	●	●
Comfort armrest in the rear	●	●
Electric Art interior styling	●	●
Lighting – active ambient lighting in 64 static colours, all colours can be selected individually. High-quality matt-white line as part of the lamellar trim with 190 integrated and individually controllable LEDs. Diverse colour moods, also with static or multicolour animated colour worlds. Driving assistance system interaction, parking and manoeuvring functions. Outline of electric driving: drive, recuperation, boost. Emotively appealing animations: welcome display or feedback in colour when adjusting the air conditioning or interaction with the voice control. Incorporation of active ambient lighting into the programmes of ENERGIZING comfort control and variable setting of the brightness for automatic day and night switchover	●	●
Lighting – Interior Light package	●	●
Memory package – electrical adjustment and memory function for front seats, steering wheel, outside mirror, heated areas of the seat cushion and seat backrest, head-up display (where fitted), four-way front lumbar support and seat cushion length. Includes PRE-SAFE® positioning function for front passenger seat	●	●
Seats – climatized (front)	●	●
Seats – electrically adjustable seats (rear)	●	●
Seats – heated (rear)	●	●

Seats – luxury head rests (rear)	●	●
Seats – multi-contour seats with ENERGIZING massage function (front)	●	●
Seats – split fold rear seats	●	●
Storage compartment under centre console	●	●
THERMOTRONIC automatic climate control	●	●
Windscreen – heated	●	●

## Steering

AMG Performance steering wheel in nappa leather	–	●
AMG Performance steering wheel in nappa leather/microfibre MICROCUT	●	–
Steering – 9° rear axle steering	●	●
Steering wheel – heated	●	●

## Paint, Trim and Upholstery

Dashboard in leather look	●	●
Paint – metallic	●	●
Roof lining – MICROCUT microfibre in black	●	●
Trim – centre console and door panels in anthracite linestructure lime wood	●	–
Trim – centre console and door panels in ship's deck open-pore walnut wood	–	●
Upholstery – AMG nappa leather	●	●

EQS53 4MATIC+ Night Edition

EQS53 4MATIC+ Touring

[Book a test drive](#)[Find your EQS](#)[Find a Showroom](#)

# Mercedes-AMG Standard equipment

● Standard    – Not available

## Safety and Assistance Systems

	EQS 53 4MATIC+ Night Edition	EQS 53 4MATIC+ Touring
Active Traffic Sign Assist <sup>1</sup>	●	●
Dashcam	●	●
Driving Assistance package Plus <sup>1</sup>	●	●
EASY-PACK tailgate	●	●
GUARD 360° vehicle protection Plus <sup>2</sup> – anti-theft protection hardware including alarm and immobilizer. Theft notification and park damage detection <sup>3</sup> , stolen vehicle locator <sup>3</sup> , 360° surroundview-camera snapshots <sup>3</sup> and remote key immobilizer <sup>3</sup>	●	●
KEYLESS-GO Comfort package	●	●
Mercedes-Benz emergency call system <sup>2,4</sup>	●	●
Parking package – Active Park Assist <sup>1</sup> , 360° camera and remote parking including a three-year subscription to Remote Parking <sup>2</sup>	●	●
Tirefit	●	●

## Communications and In-Car Entertainment

	EQS 53 4MATIC+ Night Edition	EQS 53 4MATIC+ Touring
5G communications module <sup>2</sup>	●	●
12.3-inch digital instrument cluster display	●	●
Digital radio	●	●
EQ navigation services <sup>2</sup> – navigation optimised for Mercedes-Benz EQ, range on map (range display), display of charging stations (info on availability, programming of charging settings and pre-entry climate control <sup>2</sup> including remote retrieval of charging status and range	●	●
Fingerprint scanner – colour-illuminated fingerprint scanner in the trim strip below the OLED media display, two fingerprints per user can be stored, quick access replaces PIN entry, protects personal data such as profiles plus office and payment functions	●	●
Hard-disc navigation	●	●
Live traffic information <sup>2</sup> – 3 years	●	●
MBUX augmented reality for navigation	●	●
MBUX Hyperscreen	●	●
MBUX Interior Assistant (front)	●	●
Pre-entry climate control <sup>2</sup>	●	●
Pre-installation for Car Sharing <sup>2</sup>	●	●
Sound system – Burmester® 3D surround sound system	●	●
USB package – six fast charging USB-C ports including four compatible for data transfer	●	●
Wireless charging system <sup>5</sup> for mobile devices (front and rear)	●	●
Wireless smartphone integration (front) <sup>5</sup>	●	●

<sup>1</sup>Our driver assistance and safety systems are aids and do not relieve you of your responsibility as the driver. Please take note of the information in the Owner's Manual and the system limits which are described therein

<sup>2</sup>Free of charge for three years from activation

<sup>3</sup>Please be aware Mercedes-Benz emergency call system comes as standard for the first 10 years of the vehicle's lifecycle

<sup>4</sup>The connection of the communication module to the mobile phone network including the emergency call system depends on the respective network coverage and availability of network providers

<sup>5</sup>Compatible smartphone required. For further details please visit <https://www.mercedes-benz-mobile.com/>



# Mercedes-AMG Standard equipment

● Standard    – Not available

## Services

Geofencing<sup>1</sup> – available to use free of charge for three years following activation<sup>2</sup>, denotes a specific area and notifies via push message when the vehicle leaves or enters this area

Mercedes-Benz Integrated ServiceCare – the maintenance service covers all necessary maintenance work for 6 years or 90,000 km (56,250 miles)<sup>3</sup>

Parked vehicle locator<sup>1</sup> – available to use free of charge for three years following activation<sup>2</sup>, shows the position of the parked vehicle in a radius of approx. 1.5 km

Personalisation<sup>1</sup> – available to use free of charge for three years following activation<sup>2</sup>, stores settings such as the radio station or navigation destination in the personal driver profile and enables these to be used in vehicles with the same telematics generation, the profile can be linked to the key, and the functions can therefore already be activated before getting in

Programming of auxiliary heater/ventilation<sup>1</sup>

Remote door locking and unlocking<sup>1</sup> – available to use free of charge for three years following activation<sup>2</sup>, provides convenient remote monitoring

Remote retrieval of vehicle status<sup>1,2</sup> – shows mileage, tyre pressure, washer fluid level, etc.

Remote vehicle finder<sup>1</sup> – available to use free of charge for three years following activation<sup>2</sup> indicators activated via the app help to draw attention to the vehicle, for example in large, confusing car parks

EQS 53 4MATIC+ Night Edition  
EQS 53 4MATIC+ Touring

●	●
●	●
●	●
●	●
●	●
●	●
●	●
●	●

Sliding sunroof/windows with remote closing and opening including ventilation function<sup>1</sup> to use free of charge for three years following activation<sup>2</sup> for a breath of fresh air in the vehicle available

Send2Car function<sup>1</sup> – available to use free of charge for three years following activation<sup>2</sup>, sends selected addresses via the app to the vehicle's navigation system, for example POIs or restaurants

Speedfencing<sup>1</sup>

Stolen Vehicle Help<sup>1</sup> (free of charge for 3 years from activation) – this service reduces the bureaucratic effort required and gives you an advantage in terms of time. In the event of theft, you can report it to the police. You can transfer the police file number (depending on country) plus the relevant vehicle and owner information quite simply via app to our certified partner's security centre. This centre will then coordinate with the local police station to track your vehicle

Valet protect<sup>1</sup> – available to use free of charge for 3 years following activation<sup>2</sup> notifies via the app when the ignition is switched on/off and when the vehicle moves outside a defined radius (1 km, 2.5 km or 5 km)

Vehicle Tracking<sup>1</sup>

●	●
●	●
●	●
●	●
●	●
●	●
●	●
●	●

EQS 53 4MATIC+ Night Edition  
EQS 53 4MATIC+ Touring

<sup>1</sup>The connection of the communication module to the mobile phone network including the emergency call system depends on the respective network coverage and availability of network providers. Upon expiry of the initial term, the services can be extended for a fee. Initial activation of the services is possible within 1 year of first registration or commissioning by the customer, whichever occurs first. ServiceCare as standard

<sup>2</sup>To use this service, you must register on the Mercedes-Benz portal and also accept the Terms of Use for the Digital Extras. In addition, the respective vehicle must be paired with the user account.

<sup>3</sup>The Integrated ServiceCare is fully transferrable to a new owner if there is coverage remaining. All EQS Saloon models from MY805 onwards will come with Mercedes-Benz Integrated ServiceCare as standard

# Genuine accessories

We've developed a range of accessories you can add to help personalise and enhance your EQS.

## Velour floor mats CLASSIC, set, 4-piece

Floor mats have to undergo rigorous testing before they are deemed worthy of the star logo. Available in three colours, black, space grey and macchiato beige, these mats are precision-tailored to your Mercedes-Benz. They can be clip-fastened to the floor of the vehicle to prevent slipping. Elegant, high-quality tufted velour mats with embroidered Mercedes-Benz label.

black: A29768003089J74  
 space grey: A29768003081D57  
 macchiato beige: A29768003088U20



## Coolbox

Be it cool drinks, a picnic or baby food: the thermoelectric refrigerator box cools upon request and is the perfect companion on any day out. Thanks to its extra thick insulation it can cool up to 5°C, but a max. of 20°C under the outside temperature. It fits perfectly into every Mercedes-Benz vehicle and holds 13 litres. (A0008205409)

## Rear spoiler

A rear spoiler from Mercedes-Benz significantly boosts the car's aerodynamics. Tailored to the contours of the vehicle for a sporty design. Top-class materials produce a high-quality feel. (primed: A2977930100)



## DUO plus child seat, with ISOFIX

Mercedes-Benz 'DUO PLUS', suitable for children between the ages of around 9 months to 4 years (9-18 kg). Featuring ISOFIX attachments to make securely fitting the child seat even easier. The TopTether also offers additional safety. The height-adjustable shoulder belt and three seat positions offer additional comfort. The cover with an exclusive design can be removed and washed. This has been tested to Mercedes-Benz requirements. (A0009704302)



All the above accessories are subject to availability and compatibility. Please ask your Mercedes-Benz Authorised Repairer for more information. Images shown are for illustration purposes only.



# Technical data

## ● Standard

Model		EQS 350	EQS 450+	Mercedes-AMG EQS 53 4MATIC+
<b>Model</b>				
<b>Motor</b>				
Battery type		lithium-ion high-voltage	lithium-ion high-voltage	lithium-ion high-voltage
Electric motor type		synchronous	synchronous	synchronous
Battery capacity	kWh	96	118	118
Power <sup>1</sup>	hp (kW)	292 (215)	360 (265)	658 (484)
Torque <sup>1</sup>	Nm at rpm	565	568	955
On-board charger	kW	11AC; 170 DC	11AC; 200 DC	22AC; 200 DC
Emissions standard		Euro 6e	Euro 6e	Euro 6e
<b>Transmission</b>				
Single-speed automatic		●	●	●
<b>Performance</b>				
Acceleration 0–62 mph	sec	6.7	6.2	3.8
Top speed	mph	130	130	137
Charging time				
Public Rapid charger (170 kW DC) 10–80% <sup>2</sup>		32 mins	–	–
Public Rapid charger (200 kW DC) 10–80% <sup>2</sup>		–	31 mins	31 mins
Wallbox (22 kW AC) 0–100% <sup>3</sup>		–	–	6 hrs 15 mins
Wallbox (11 kW AC) 0–100% <sup>3</sup>		10 hrs 15 mins	12 hrs 15 mins	–
Home wallbox (7.4 kW AC) 0–100% <sup>3</sup>		15 hrs	18 hrs 30 mins	18 hrs 30 mins
Energy consumption combined <sup>4,5</sup>	Wh/km	172–186	175–191	216–238
Electric range – WLTP <sup>4</sup>	miles	378–409	444–481	339–378
		Please see <b>page 63</b> for more details	Please see <b>page 63</b> for more details	Please see <b>page 63</b> for more details

<sup>1</sup>Figures according to Regulation (EC) No. 595/2009 in the currently applicable version <sup>2</sup>Specified voltage and current values refer to network infrastructure and can be limited by the vehicle. Times are from 10–80% charge using public rapid charging at 200 kW <sup>3</sup>Specified voltage and current values refer to network infrastructure and can be limited by the vehicle. Times are from 0–100% charge using a wallbox (three-phase) or standard socket (single-phase) <sup>4</sup>Figures shown are for comparability purposes; only compare with other cars tested to the same technical procedures. Figures may not reflect real life driving results, which will depend upon a number of factors including the starting charge of the battery, factory-fitted options, accessories fitted (post registration), variations in weather, driving styles and vehicle load. Further information about the test used to establish range, power consumption and CO<sub>2</sub> figures can be found at <http://www.mercedes-benz.co.uk/WLTP> <sup>5</sup>Specified voltage and current values refer to network infrastructure and can be limited by the vehicle

[Book a test drive](#)[Find your EQS](#)[Find a Showroom](#)

# Technical data

Model	EQS 350	EQS 450+	Mercedes-AMG EQS 53 4MATIC+
<b>Weights and capacities</b>			
Kerb weight <sup>6</sup>	kg 2,611–2,660	2,712–2,760	2,876–2,908
Perm. Gross Vehicle Weight	kg 3,035	3,110	3,225
Boot capacity – seats up/down	l 620/1,700	620/1,700	580
Towing capacity – unbraked/braked	kg 750/750	750/750	750/750
Turning circle	m 11.9	11.9	11.52
<b>Insurance</b>			
All variants	50E	50E	50E
Insurance ratings may vary depending on model line and specification.			

<sup>6</sup>Mass of the vehicle in running order with at least 90% full fuel tank, plus the mass of the driver (estimated by law at 75 kg), fuel and fluids, equipped with the standard equipment as specified by the manufacturer as well as, where applicable, the mass of the body, cab, trailer coupling and spare wheel(s) as well as tools. Optional extras, additional equipment and accessories can influence the weight, residual payload, rolling resistance, aerodynamics, etc., and therefore also affect the consumption/CO<sub>2</sub> values



[Book a test drive](#)[Find your EQS](#)[Find a Showroom](#)

# Electric range and consumption

Model	Energy Consumption – combined (Wh/km) <sup>1</sup>	All Electric Range (km) <sup>1</sup>	All Electric Range (miles) <sup>1</sup>
EQS 350 AMG Line Premium	172	658	409
EQS 350 AMG Line Premium Plus	173	654	406
EQS 350 Business Class	186	610	379
EQS 350 Business Class + Rear Luxury Lounge package	186	609	378
EQS 350 Business Class + Extended Rear Luxury Lounge package	186	609	378
EQS 350 Business Class + Rear Luxury Lounge package + MBUX High-End Rear Seat Entertainment System	186	608	378
EQS 350 Business Class + Extended Rear Luxury Lounge package + MBUX High-End Rear Seat Entertainment System	186	608	378
EQS 450+ AMG Line Premium	175	774	481
EQS 450+ AMG Line Premium Plus	177	770	479
EQS 450+ Business Class	190	718	446
EQS 450+ Business Class + Rear Luxury Lounge package	190	717	446
EQS 450+ Business Class + Extended Rear Luxury Lounge package	190	717	446
EQS 450+ Business Class + Rear Luxury Lounge package + MBUX High-End Rear Seat Entertainment System	190	716	445
EQS 450+ Business Class + Extended Rear Luxury Lounge package + MBUX High-End Rear Seat Entertainment System	191	715	444
Mercedes-AMG EQS 53 4MATIC+ Night Edition	216	608	378
Mercedes-AMG EQS 53 4MATIC+ Touring	237	549	341
Mercedes-AMG EQS 53 4MATIC+ Touring + Rear Luxury Lounge package	237	548	341
Mercedes-AMG EQS 53 4MATIC+ Touring + Extended Rear Luxury Lounge package	237	547	340
Mercedes-AMG EQS 53 4MATIC+ Touring + Rear Luxury Lounge package + MBUX High-End Rear Seat Entertainment System	238	547	340
Mercedes-AMG EQS 53 4MATIC+ Touring + Extended Rear Luxury Lounge package + MBUX High-End Rear Seat Entertainment System	238	546	339

<sup>1</sup>Figures shown are for comparability purposes; only compare with other cars tested to the same technical procedures. Figures may not reflect real life driving results, which will depend upon a number of factors including the starting charge of the battery, factory-fitted options, accessories fitted (post registration), variations in weather, driving styles and vehicle load. Further information about the test used to establish range, power consumption and CO<sub>2</sub> figures can be found at <http://www.mercedes-benz.co.uk/WLTP>



Book a test drive



Find your EQS



Find a Showroom

## EQS 350/450+

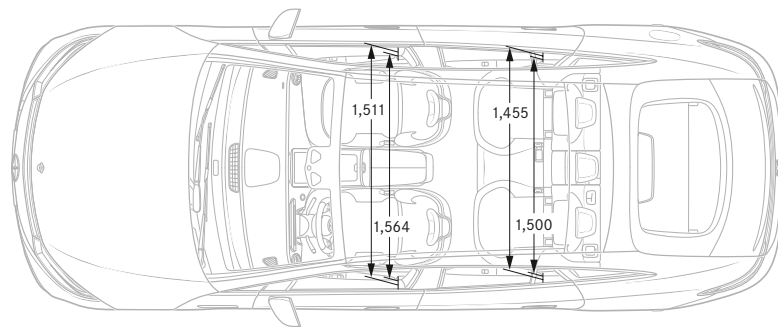
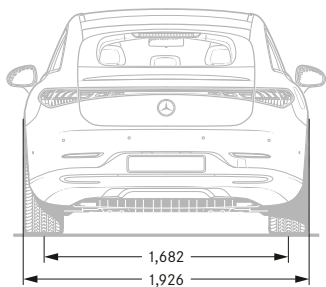
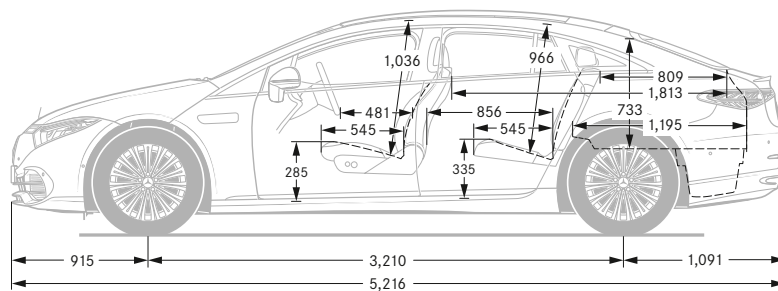
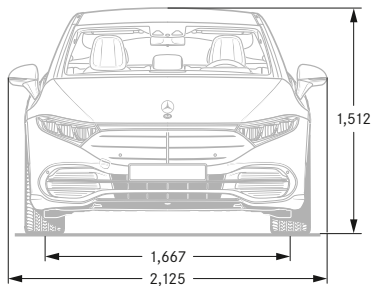

All measurements in millimetres. The dimensions shown are mean values and apply to standard-specification, unladen vehicles. Dimensions may vary slightly depending on the engine. Please consult your Mercedes-Benz Agent for further information

Design	Technology	Safety	Model lines	Model prices	Mercedes-AMG	Mercedes-AMG prices	Personalisation	Standard equipment	Genuine accessories	Technical data	Additional information
--------	------------	--------	-------------	--------------	--------------	---------------------	-----------------	--------------------	---------------------	----------------	------------------------



Book a test drive



Find your EQS



Find a Showroom

# Mercedes-AMG EQS 53 4MATIC+

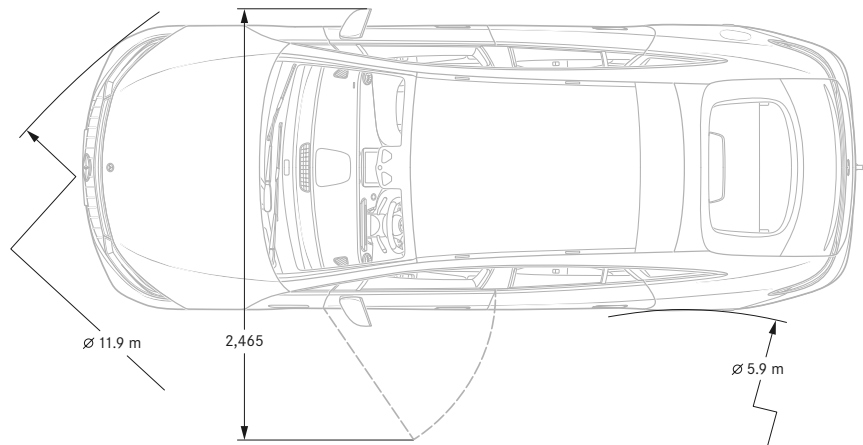
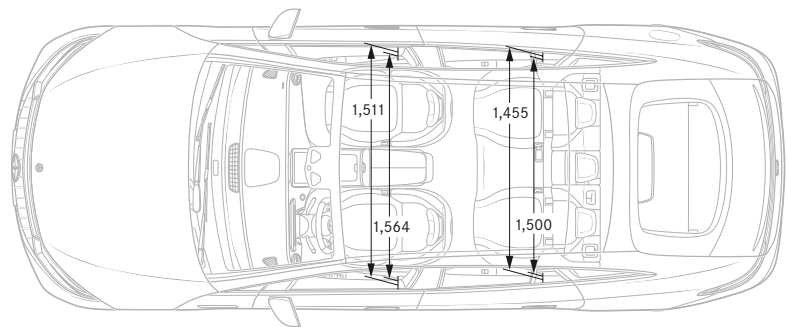
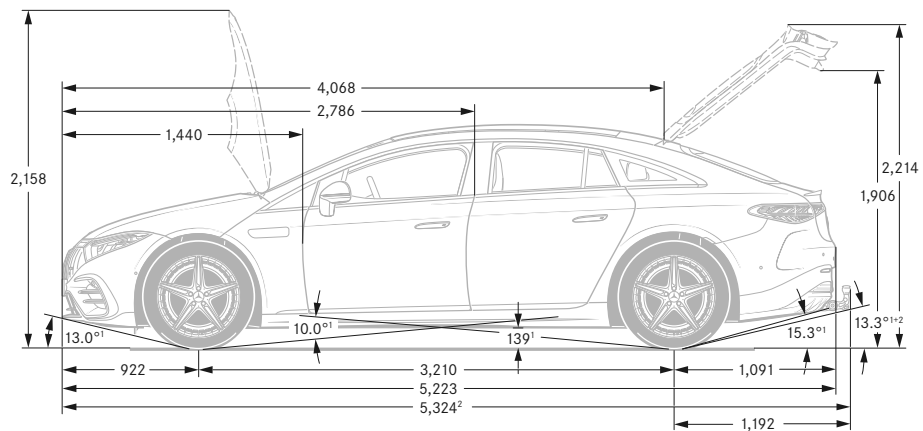
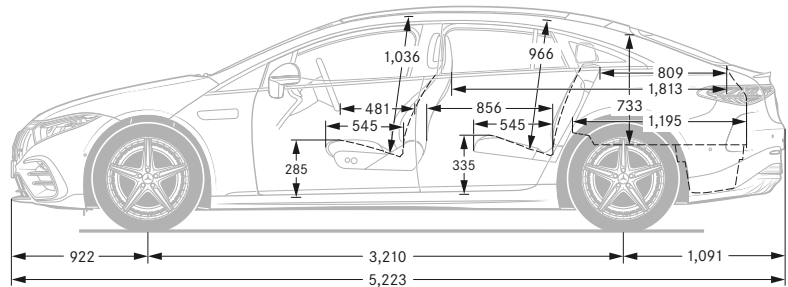

<sup>1</sup>At perm. gross vehicle weight <sup>2</sup>With trailer coupling incl. protective cap (optional) All measurements in millimetres. The dimensions shown are mean values and apply to standard-specification, unladen vehicles

Design	Technology	Safety	Model lines	Model prices	Mercedes-AMG	Mercedes-AMG prices	Personalisation	Standard equipment	Genuine accessories	Technical data	Additional information
--------	------------	--------	-------------	--------------	--------------	---------------------	-----------------	--------------------	---------------------	----------------	------------------------



# Road Fund Licence

All road vehicle registrations are subject to Vehicle Excise Duty (Road Fund Licence), which varies in accordance with the vehicle's CO<sub>2</sub> emissions. A first year rate for each taxation band will apply. The table below shows the bands (A–M) created by the DVLA and the corresponding Road Fund Licence. CO<sub>2</sub> emissions and the relevant Excise Duty are shown on the model pricing page.

## VED applicable for registrations up to 31 March 2025

Band	CO <sub>2</sub> emissions (g/km)	First year rate petrol and RDE2 diesel (£)	First year rate alternative fuel (£)	Electric vehicles		Alternative fuel vehicles		Petrol/diesel vehicles	
				Standard rate (£)	Premium rate (£) <sup>1</sup>	Standard rate (£)	Premium rate (£) <sup>1</sup>	Standard rate (£)	Premium rate (£) <sup>1</sup>
A	0	0.00	0.00	0.00	0.00	0.00	0.00	0.00	0.00
B	1 to 50	10.00	0.00	0.00	0.00	180.00	590.00	190.00	600.00
C	51 to 75	30.00	20.00	0.00	0.00	180.00	590.00	190.00	600.00
D	76 to 90	135.00	125.00	0.00	0.00	180.00	590.00	190.00	600.00
E	91 to 100	175.00	165.00	0.00	0.00	180.00	590.00	190.00	600.00
F	101 to 110	195.00	185.00	0.00	0.00	180.00	590.00	190.00	600.00
G	111 to 130	220.00	210.00	0.00	0.00	180.00	590.00	190.00	600.00
H	131 to 150	270.00	260.00	0.00	0.00	180.00	590.00	190.00	600.00
I	151 to 170	680.00	670.00	0.00	0.00	180.00	590.00	190.00	600.00
J	171 to 190	1,095.00	1,085.00	0.00	0.00	180.00	590.00	190.00	600.00
K	191 to 225	1,650.00	1,640.00	0.00	0.00	180.00	590.00	190.00	600.00
L	226 to 255	2,340.00	2,330.00	0.00	0.00	180.00	590.00	190.00	600.00
M	over 255	2,745.00	2,735.00	0.00	0.00	180.00	590.00	190.00	600.00



Some of the model features, optional extras and colours shown may not be available, or may only be available in a different specification, or at a different price.

<sup>1</sup>Premium rate only applicable to vehicles where the list price is over £40,000 including any factory-fitted options, standard UK delivery charge and VAT



# Services and insurance

## Mercedes-Benz Service Plans

We believe that servicing and repair costs should be as flexible and affordable as possible for your EQS, which is why we offer a choice of Service Plans to make it easy to budget for all your servicing, MOT and repair costs. It spreads your bills into manageable monthly payments based on whether you have a new or used Mercedes-Benz.

- **ServiceCare** – guarantees the price of parts and labour for up to four services and safeguards against any inflationary influences. It also covers your annual MOT fees depending on the age of your vehicle when you take your plan out.
- **CompleteCare** – our most comprehensive plan covering all your servicing, MOT, wear & tear needs as well as Extended Warranty once your vehicle turns four years old.
- **Extended Warranty** – protect yourself against sudden or unexpected repair costs after your initial warranty period has ended after three years. There are three policy options to choose from: 12-month, 24-month or a monthly pay-as-you-go option.

[› Click here for more information](#)

## Motor Insurance

We know that once you have chosen your Mercedes-Benz you can't wait to drive it – that's why we created First Cover<sup>1</sup>. It gives you 5 days' free comprehensive Motor Insurance when you buy a new or used vehicle from a Mercedes-Benz Agent. We will also send you a quote for annual cover, so you can enjoy the same peace of mind all year round.

[› Apply for First Cover](#)

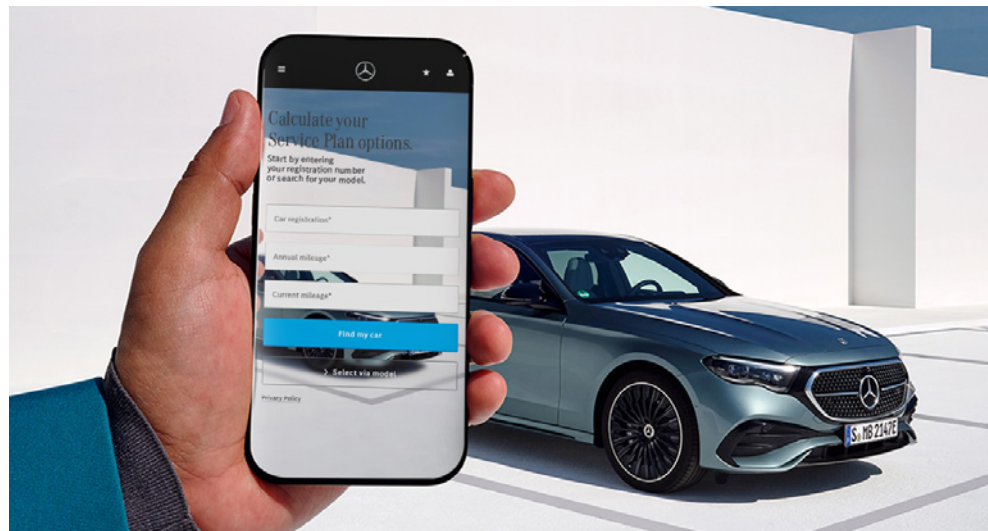

## Battery Warranty

The battery is under warranty for either a maximum distance of 100,000 miles or up to eight years from the date of first registration, whichever comes first.

## Warranty and breakdown cover

Every Mercedes-Benz comes with a three-year unlimited mileage warranty against manufacturing or material defects<sup>2</sup> and up to 30 years warranty against perforation due to corrosion from the inside out.<sup>3</sup> What's more, it's also covered by Mercedes-Benz Roadside Assistance – a unique package comprising up to 30 years pan-European breakdown assistance.<sup>3</sup>

<sup>1</sup>Applies to vehicles sold by Mercedes-Benz in the UK to its franchised Mercedes-Benz Agents

<sup>2</sup>Subject to full Terms and Conditions, dependent on date of registration, available upon request

<sup>3</sup>Terms and Conditions apply. We are an independent intermediary dealing with selected insurers in respect of annual insurance

Design	Technology	Safety	Model lines	Model prices	Mercedes-AMG	Mercedes-AMG prices	Personalisation	Standard equipment	Genuine accessories	Technical data	Additional information
--------	------------	--------	-------------	--------------	--------------	---------------------	-----------------	--------------------	---------------------	----------------	------------------------



Effective from December 2024 Production. Information correct at time of publication 08.10.2024.

Prices and specifications are subject to change without prior notice.

MBV297PL/0225 MY805.5

