



# The new EQS SUV

Effective from August 2023 Production.

MERCEDES-EQ

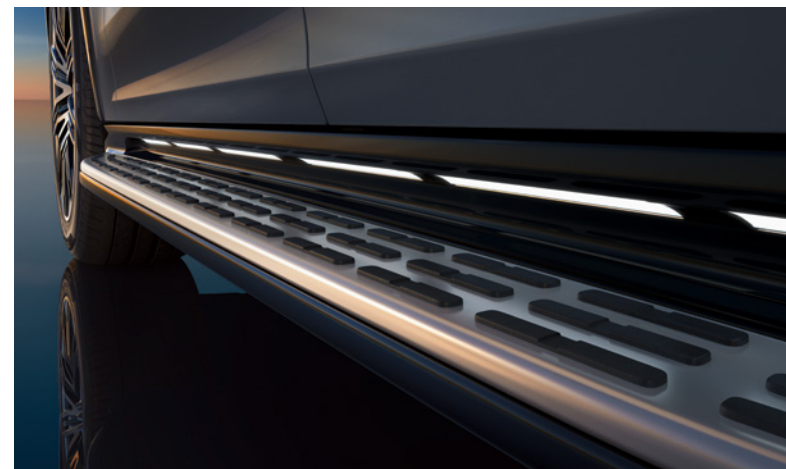

[Book a test drive](#)[Find your EQS SUV](#)[Find a Showroom](#)

Some of the model features, optional extras and colours shown may not be available, or may only be available in a different specification, or at a different price.

<a href="#">Design</a>	<a href="#">Technology</a>	<a href="#">Safety</a>	<a href="#">Mercedes-EQ</a>	<a href="#">Model lines</a>	<a href="#">Upholstery</a>	<a href="#">Model prices</a>	<a href="#">Personalisation</a>	<a href="#">Standard equipment</a>	<a href="#">Genuine accessories</a>	<a href="#">Technical data</a>	<a href="#">Additional information</a>
------------------------	----------------------------	------------------------	-----------------------------	-----------------------------	----------------------------	------------------------------	---------------------------------	------------------------------------	-------------------------------------	--------------------------------	--



Book a test drive



Find your EQS SUV



Find a Showroom



Some of the model features, optional extras and colours shown may not be available, or may only be available in a different specification, or at a different price.

Design	Technology	Safety	Mercedes-EQ	Model lines	Upholstery	Model prices	Personalisation	Standard equipment	Genuine accessories	Technical data	Additional information
--------	------------	--------	-------------	-------------	------------	--------------	-----------------	--------------------	---------------------	----------------	------------------------



Book a test drive



Find your EQS SUV



Find a Showroom



Some of the model features, optional extras and colours shown may not be available, or may only be available in a different specification, or at a different price.

Design	Technology	Safety	Mercedes-EQ	Model lines	Upholstery	Model prices	Personalisation	Standard equipment	Genuine accessories	Technical data	Additional information
--------	------------	--------	-------------	-------------	------------	--------------	-----------------	--------------------	---------------------	----------------	------------------------



Book a test drive



Find your EQS SUV



Find a Showroom



Some of the model features, optional extras and colours shown may not be available, or may only be available in a different specification, or at a different price.

<a href="#">Design</a>	<a href="#">Technology</a>	<a href="#">Safety</a>	<a href="#">Mercedes-EQ</a>	<a href="#">Model lines</a>	<a href="#">Upholstery</a>	<a href="#">Model prices</a>	<a href="#">Personalisation</a>	<a href="#">Standard equipment</a>	<a href="#">Genuine accessories</a>	<a href="#">Technical data</a>	<a href="#">Additional information</a>
------------------------	----------------------------	------------------------	-----------------------------	-----------------------------	----------------------------	------------------------------	---------------------------------	------------------------------------	-------------------------------------	--------------------------------	--



Book a test drive



Find your EQS SUV



Find a Showroom



EQS SUV

# Technology

[Design](#)

[Technology](#)

[Safety](#)

[Mercedes-EQ](#)

[Model lines](#)

[Upholstery](#)

[Model prices](#)

[Personalisation](#)

[Standard equipment](#)

[Genuine accessories](#)

[Technical data](#)

[Additional information](#)



Book a test drive



Find your EQS SUV



Find a Showroom

# Mercedes-Benz User Experience (MBUX)

Transforming the in-car user experience, thanks to MBUX: Controlled via voice, touch or gesture (where fitted) input, the innovative infotainment system can over time even predict personal habits thanks to artificial intelligence.

## Voice control

- Activated by the keywords “Hey Mercedes”, the new intelligent voice control LINGUATRONIC<sup>1</sup> lets you control many of the infotainment functions, including destination input, phone calls or music selection
- MBUX is able to understand different accents and will adjust to you over time
- MBUX even understands indirect commands. Feeling chilly? Just say “I feel cold” and MBUX will adjust the temperature for you
- MBUX is able to understand which individual seat the request has come from, and will therefore only respond to their specific request (e.g. adjusting the temperature for just the front passenger)

## Personalisation

- Turn the new EQS SUV into your very own Mercedes-Benz by personalising driving modes, radio stations, ambient lighting and much more
- Your personal settings can be saved in up to seven different profiles, making your driving experience the best one possible
- Thanks to artificial intelligence, MBUX is able to learn and adapt over time. It will be able to predict your personal habits, such as navigation for frequently-driven routes, or the radio station you like to listen to on your way home from work

## Touch inputs

- Beside voice control you can operate MBUX via touchscreen, the touch controls on the centre console, as well as touch control buttons on the steering wheel

## Maintenance and service

- Wondering when the next service is due? Or how much further you can drive until you need to stop at a charging station? Just ask your MBUX – it will tell you the answer



The connection of the communication module to the mobile phone network including the emergency call system depends on the respective network coverage and availability of network providers

<sup>1</sup>LINGUATRONIC off-board functions are currently only available for three years

Design	Technology	Safety	Mercedes-EQ	Model lines	Upholstery	Model prices	Personalisation	Standard equipment	Genuine accessories	Technical data	Additional information
--------	------------	--------	-------------	-------------	------------	--------------	-----------------	--------------------	---------------------	----------------	------------------------

# Mercedes me connect

 Stay connected any time, anywhere.

# Mercedes me

Mercedes me is a range of innovative online services designed to enhance your Mercedes-Benz experience. Accessible via mobile, tablet or PC, Mercedes me lets you enjoy the highest standards of care and support, in a way that integrates seamlessly with your busy lifestyle.

### Safety and Service – Mercedes me connect helps to keep you and your car safe

Check your car's washer fluid level, tyre pressure and battery level from your phone so you'll be ready for every journey.

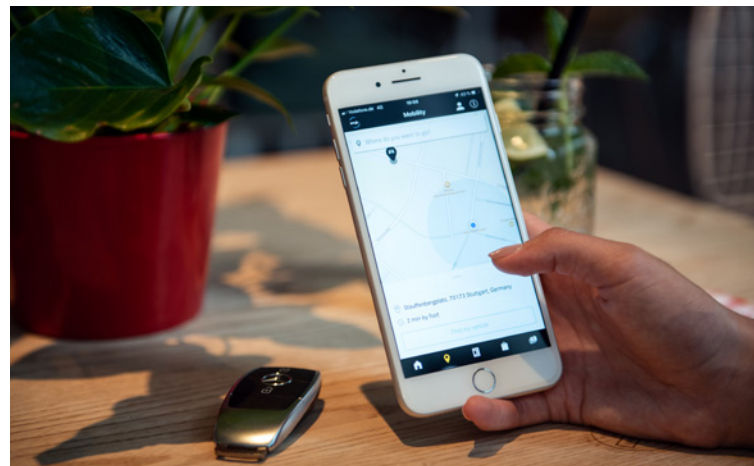

### Live Traffic Information, Parked Vehicle Locator and much more with Mercedes me connect

Forgot where you've parked? Parked Vehicle Locator<sup>1</sup> will show you exactly where your car is as long as you're in a 1-mile radius of where you parked. Real-time traffic data and dynamic route with shorter journey times.

For more information speak to your local Mercedes-Benz Agent or visit the Mercedes me connect store at [shop.mercedes-benz.com/en-gb/connect](http://shop.mercedes-benz.com/en-gb/connect)

### Comfort – connect to your car anytime, anywhere

Forgot to lock your car? With Remote Car Lock<sup>2</sup> you will receive a notification on your smartphone to let you know. With one tap, you can lock and unlock your vehicle so you never have to worry.

### Mercedes-EQ specific services

Check your charging status on the go and programme your pre-entry climate control and charging settings remotely. The Mercedes-EQ specific navigation considers electrical range, topography and charging stations.

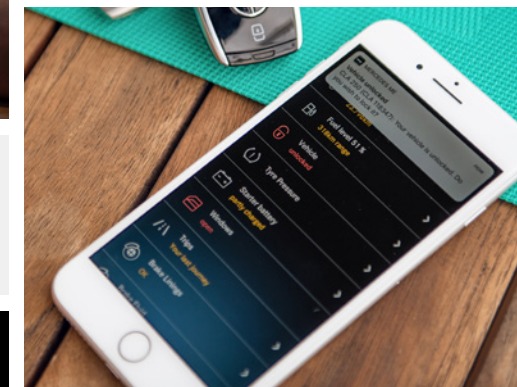

<sup>1</sup>The connection of the communication module to the mobile phone network including the emergency call system depends on the respective network coverage and availability of network providers

<sup>2</sup>Available on all models with the Vehicle Monitoring package. This option may vary between standard and additional cost dependent on the model

<sup>3</sup>Part of the Vehicle Status package. This option may vary between standard and additional cost dependent on the model

Images shown are for illustration purposes only

Design	Technology	Safety	Mercedes-EQ	Model lines	Upholstery	Model prices	Personalisation	Standard equipment	Genuine accessories	Technical data	Additional information
--------	------------	--------	-------------	-------------	------------	--------------	-----------------	--------------------	---------------------	----------------	------------------------





Book a test drive



Find your EQS SUV



Find a Showroom

EQS SUV

# Safety



Design	Technology	Safety	Mercedes-EQ	Model lines	Upholstery	Model prices	Personalisation	Standard equipment	Genuine accessories	Technical data	Additional information
--------	------------	--------	-------------	-------------	------------	--------------	-----------------	--------------------	---------------------	----------------	------------------------

# DIGITAL LIGHT

High-definition headlamps with innovative features.

The new innovative DIGITAL LIGHT headlamps works like a projector with more than one million pixels per headlamp and responds with brilliant light to changing traffic, road or weather conditions. Its ULTRA RANGE Highbeam with 650 m makes you feel like driving at daylight.

**Standard on all model lines**





Book a test drive



Find your EQS SUV



Find a Showroom

# Driving Assistance package Plus Cares for what matters.

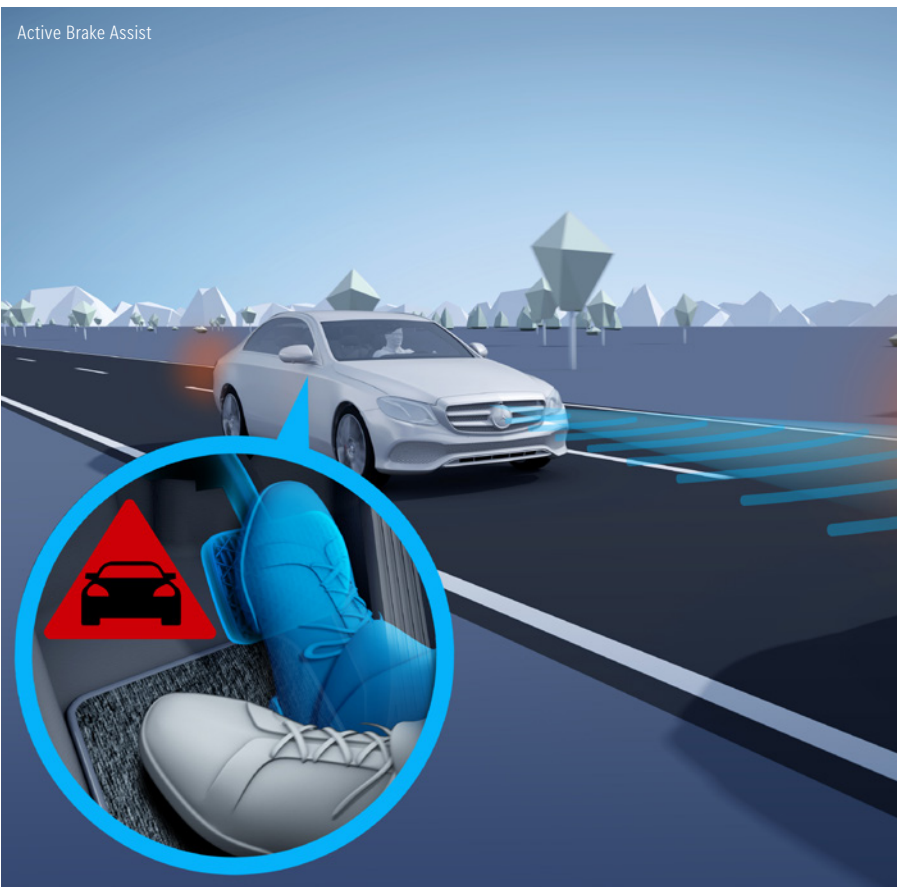

Active Brake Assist

The new EQS SUV comes with standard ground-breaking innovations in safety, comfort and driving functions, to help you stay safe on the road.

## Driving Assistance package Plus<sup>1</sup> (code P20) – designed and priced as a package Standard on all model lines

**Active Blind Spot Assist** expanded with blind spot monitoring towards the front and side. Additional hazard indication of the blind spot warning system as well as exit warning function

**Active Brake Assist with cross-traffic function** now with turning manoeuvre function (responding to (among other things) crossing pedestrians when making a turn). Operating range on urban routes expanded to 74 mph (previously 44 mph)

**Active Distance Assist DISTRONIC** now responds to stationary road users to prevent collisions up to 80 mph (previously 37 mph)

**Active Emergency Stop Assist:** now able to assist in manual mode (previously on in DISTRONIC mode). Optional lane change by one lane (at 49 mph where no obstacles detected)

**Active Evasive Steering Assist:** now responds to cyclists and ends of tailbacks in addition to pedestrians. Operating range on urban routes expanded to 67 mph (previously 44 mph)

**Active Lane Keeping Assist** with enhanced comfort thanks to active steering intervention (instead of braking intervention) and additional hazard indication

**Active Speed Limit Assist** ensures detected speed limits are automatically adopted as the set speed for Active Distance Assist DISTRONIC

### Active Traffic Sign Assist

### Congestion emergency braking function

### Exit warning function when hand moves towards the door handles

### Extended automatic restart on motorways

### Hazard display via ambience lighting

Increased availability and cornering performance on carriageways with **Active Steering Assist**, more stern warnings to put hands on the steering wheel with new capacitive steering wheel

**PRE-SAFE® PLUS and Impulse Side with body-raising function:** when a rear-end collision threatens, PRE-SAFE® PLUS can initiate preventive measures, including warning following traffic and locking the brakes on standstill

**Route-based speed adjustment with end of traffic jam function and Active Stop-and-Go Assist** adaption of speed before curves, roundabouts and junctions with end of traffic jam function

<sup>1</sup>Our driver assistance and safety systems are aids and do not relieve you of your responsibility as the driver. Please take note of the information in the Owner's Manual and the system limits which are described therein

Design	Technology	Safety	Mercedes-EQ	Model lines	Upholstery	Model prices	Personalisation	Standard equipment	Genuine accessories	Technical data	Additional information
--------	------------	--------	-------------	-------------	------------	--------------	-----------------	--------------------	---------------------	----------------	------------------------



Book a test drive



Find your EQS SUV



Find a Showroom



EQS SUV

# Mercedes-EQ

Design

Technology

Safety

Mercedes-EQ

Model lines

Upholstery

Model prices

Personalisation

Standard equipment

Genuine accessories

Technical data

Additional information

[Book a test drive](#)[Find your EQS SUV](#)[Find a Showroom](#)

# EQS SUV

# MERCEDES-EQ

Vehement power immediately from standstill: An electric motor at both the front and rear axle converts electrical into mechanical energy, and delivers impressive forward thrust. The intelligent operating strategy of the powertrain components supplies the power always wherever it is needed at the moment – efficiently and nearly silently.

## EQS 450 4MATIC SUV

Battery electric vehicle, 360 hp/265 kW  
Electric range 362–364 miles – WLTP

OTR from **£129,470<sup>1</sup>**

## EQS 580 4MATIC SUV

Battery electric vehicle, 544 hp/400 kW  
Electric range 362–363 miles – WLTP

OTR from **£139,470<sup>1</sup>**



### Standard equipment

AC charging system rated at 22 kW

AIRMATIC air suspension

Charging cable for wallbox and public charging stations, Type 2 (Mode 3) – 5 metres

Charging socket

DC charging system rated at 200 kW

Pre-entry climate control<sup>2</sup>

Radar-based recuperation

### Technical details

Electric range <sup>3</sup>	362–364 miles
Charging time	
Public Rapid charger (200 kW DC) 10–80% <sup>4</sup>	31 mins
Wallbox (22 kW AC) 10–100% <sup>5</sup>	5 hrs 30 mins
Home wallbox (7.4 kW AC) 10–100% <sup>5</sup>	16 hrs 45 mins
Range power consumption, combined <sup>3,6</sup>	212–211 Wh/km
Battery type (capacity)	lithium-ion (108.4 kWh)
Capacity on-board charger	22 kW AC; 200 kW DC

### Attention



Please be aware that external factors such as weather, gradient and ambient temperature amongst others can significantly impact range.



Please also note that internal factors such as driving style and climate control settings etc. can also significantly impact range.



Using the pre-entry climate control<sup>2</sup> when plugged into a charge point will ensure the perfect ambience and ensure that your car is just how you like it, as well as making sure that your battery isn't used unnecessarily to heat/cool the vehicle (maximising range).

<sup>1</sup>The recommended on-the-road price includes the Road Fund Licence applicable to the standard model plus delivery charge (£780.00 incl. VAT), new vehicle registration fee (£55.00) and number plates (£25.00 incl. VAT). VAT is calculated at the standard rate of 20%. Some of the model features, optional extras and colours shown may not be available, or may only be available in a different specification, or at a different price. <sup>2</sup>The connection of the communication module to the mobile phone network including the emergency call system depends on the respective network coverage and availability of network providers. <sup>3</sup>Figures shown are for comparability purposes; only compare with other cars tested to the same technical procedures. Figures may not reflect real life driving results, which will depend upon a number of factors including the starting charge of the battery, factory-fitted options, accessories fitted (post registration), variations in weather, driving styles and vehicle load. Further information about the test used to establish range, power consumption and CO<sub>2</sub> figures can be found at <http://www.mercedes-benz.co.uk/WLTP>. <sup>4</sup>Specified voltage and current values refer to network infrastructure and can be limited by the vehicle. Times are from 10–80% charge using public rapid charging at 200 kW. <sup>5</sup>Specified voltage and current values refer to network infrastructure and can be limited by the vehicle. Times are from 10–100% charge using a wallbox (three-phase) or standard socket (single-phase). <sup>6</sup>Specified voltage and current values refer to network infrastructure and can be limited by the vehicle.

## Mercedes me Charge<sup>1</sup> Features.

Mercedes me Charge<sup>1</sup> provides access to a multitude of public charging stations located in shopping centres, hotels or at motorway services. A smartphone app as well as the vehicle's navigation system show the precise location, current availability and price at the selected charging station.

### Tens of thousands charging stations in the UK

Growing network of charging providers includes bp pulse the largest charging network in the UK. Customers also get six months free bp pulse membership which reduces the electricity price when charging.



<sup>1</sup>The connection of the communication module to the mobile phone network including the emergency call system depends on the respective network coverage and availability of network providers

<sup>2</sup>With the Mercedes me connect IONITY unlimited service, charging costs are only included for EQS customers for one year from activation of the service. Please note that this exclusive offer is applicable to the first registered owner of the vehicle only and expires at the end of a period of one year from the activation of the service and cannot be transferred to third parties

### Access to fast-charging stations

Enables customers to get access to charging stations of different providers with:

- Mercedes me app
- RFID card
- Mercedes-EQ Vehicle Head unit

### Charging with IONITY

IONITY unlimited – free rapid charging for one year at all IONITY stations.<sup>2</sup>

### Green charging

All charging using Mercedes me Charge<sup>1</sup>, will be retrospectively 'greened' by Mercedes-Benz. Please click [here](#) for more info.

### Transparent and easy billing

One invoice charging processes for payment.

### Easy access

Charging stations are displayed in Mercedes me app and in MBUX multimedia system.

### No fees

Mercedes me Charge<sup>1</sup> is standard with EQS SUV.

### Charging settings and pre-entry climate control<sup>1</sup>

Enjoy your feel-good temperature when you enter your vehicle. You can simply preheat or precool the interior by setting the temperature via the Mercedes me app. In addition, the current charge status can be retrieved at any time using the Mercedes me app.

### Navigation with Electric Intelligence

Offering you the greatest possible planning security on the road. Many items of information, such as a fast and convenient route, current state of battery charge, weather data and charging infrastructure, are interlinked. A convenient and time-efficient route is then suggested to you, including charging stops if necessary.



# Mercedes me Charge<sup>1</sup> Tariffs.

For more transparency and predictability, enjoy numerous features tailored to your charging habits with the new Mercedes me Charge<sup>1</sup> fixed-priced tariffs S, M and L. Owners of a new Mercedes-EQ model will be entitled to the Mercedes me Charge<sup>1</sup> tariff L free of charge for the duration of 12 months.

## Tariff L

Recommended for 'frequent drivers'

Choose our tariff L to benefit from the best fixed prices for public charging, including discounted rapid-charging at IONITY charging stations<sup>2</sup> as well as all Mercedes me Charge<sup>1</sup> features. This tariff is recommended for frequent and long-distance drivers.

Consisting of:

- All Mercedes me Charge<sup>1</sup> features
- Fixed prices per kWh (AC: £0.45/kWh; DC: £0.53/kWh)<sup>3</sup>
- IONITY rapid-charging stations discounted (£0.53/kWh)<sup>2</sup>

**Free of charge for the duration of 12 months.**

**Thereafter:**

**£10.90/month**

## Tariff M

Recommended for 'regular drivers'

Should you wish to downgrade your tariff package after 12 months but still want to benefit from fixed prices, discounted rapid-charging at IONITY charging stations<sup>2</sup> and complete transparency, choose tariff M. This tariff is recommended for regular drivers.

Consisting of:

- All Mercedes me Charge<sup>1</sup> features
- Fixed prices per kWh (AC: £0.52/kWh; DC: £0.61/kWh)<sup>3</sup>
- IONITY rapid-charging stations discounted (£0.61/kWh)

**£4.90/month**

## Tariff S

Recommended for 'casual drivers'

Should you wish to downgrade your tariff package after 12 months, there is the option to go for tariff S, which still offers you all the Mercedes me Charge<sup>1</sup> features based on flexible prices per kWh. This tariff is recommended for casual drivers.

Consisting of:

- All Mercedes me Charge<sup>1</sup> features
- Flexible prices per kWh

**£0/month**



<sup>1</sup>The connection of the communication module to the mobile phone network including the emergency call system depends on the respective network coverage and availability of network providers applicable to the first registered owner of the vehicle only and expires at the end of a period of one year from the activation of the service and cannot be transferred to third parties [charge.mercedes.me/web/en/daimler-gb/tariffs](https://www.charge.mercedes.me/web/en/daimler-gb/tariffs) <sup>2</sup>With the Mercedes me connect IONITY unlimited service, charging costs are only included for EQS customers for one year from activation of the service. Please note that this exclusive offer is applicable to the first registered owner of the vehicle only and expires at the end of a period of one year from the activation of the service and cannot be transferred to third parties <sup>3</sup>Tariff rate excludes the BP Pulse charging network Price information is not guaranteed and is subject to change. Definitive price information can be found on the Digital Charging Solutions page: <https://eu.charge.mercedes.me/web/en/daimler-gb/tariffs>

# Next generation of home EV charging with Ohme

Mercedes-Benz plug-in vehicle customers with off-street parking can benefit from the convenience and speed of charging at home by installing an Ohme charger.

## Home charging with Ohme: from £925\* incl. VAT and standard installation

### Key benefits of Ohme:

Ohme specialise in providing future-proof electric vehicle charging solutions, in particular smart, affordable and easy-to-use charging products.

Save money: If you have a time-of-use tariff or a variable tariff, you'll pay less for your electricity at certain times of the day. Ohme uses your tariff information to charge your vehicle when the price is low to maximise your savings.

Ohme is the only EV charging provider to integrate with all energy tariffs, including Intelligent Octopus and OVO Charge Anytime – the next generation, smart EV charging tariffs.

Easy installation process.

Choice of tethered or untethered units.

Award-winning customer service – check Trustpilot for more information.

A 3-year warranty is included.

Connect your charger to the Ohme smartphone app to unlock smarter and cheaper charging at home. Easy-to-use, the Ohme app will give you full control to get more from your EV.

Ohme's chargers are compliant with the UK New Smart Charger Regulations for complete peace of mind.

### OZEV Grant:

You may be entitled to claim for an OZEV grant towards the cost of your home charger!  
To find out whether you are entitled please contact your local Mercedes-Benz Agent.

### Questions?

Please contact your local Mercedes-Benz Agent to submit an enquiry to your chosen charging partner on your behalf. To find your local Mercedes-Benz Agent, please click the button at the top right hand corner.

### Warning!

If you are planning to charge your Mercedes-Benz plug-in electric vehicle using a 3-pin domestic plug socket you must get a qualified electrician to inspect and sign off the socket to confirm it is safe and suitable to charge your vehicle. Do not use an electric vehicle 3-pin charge cable with an extension cord.



\*Price excludes £350 OZEV EVHS Grant. Price correct at time of publication, subject to change  
†The home charger £350 Grant (including VAT) is only available to customers who meet the criteria of the Office for Zero Emission Vehicles (OZEV). For full details and eligibility criteria for the OZEV EVHS Grant, see <https://www.gov.uk/government/publications/electric-vehicle-homecharge-scheme-guidance-for-customers-version-21>.



# Home charging with Pod Point Simple, convenient, fast charging.

Mercedes-Benz plug-in vehicle customers with off-street parking can benefit from the convenience and speed of charging at home by installing a Pod Point home charger.

## Home charging with Pod Point: from £925\* incl. VAT and standard installation

For full terms and conditions please visit <https://pod-point.com/legal/home-charger-terms-of-sale>

### Key benefits of Pod Point:

Pod Point is one of the leading provider of EV charging in the UK with over 200,000 home chargepoints installed.

A comprehensive 3 year 'swap out' warranty is included.

Auto Power Balancing lets you adjust your charge so that your electrical supply doesn't get overloaded when your home is using a lot of energy.

Built-in earthing protection removes the needs for expensive earth rods.

Choice of tethered or untethered units; £925 for a 7 kW universal, and £975 for 7 kW tethered

The Pod Point public network consists of over 9,200 charging bays across the UK.

5 year warranty as standard, free of charge

The standard installation package includes up to 15m of external cabling.

Utilise charge scheduling in conjunction with an off-peak EV tariff to reduce your charging costs by 70% compared with the current Energy Price Cap.<sup>1</sup>

### OZEV Grant:

You may be entitled to claim for an OZEV grant towards the cost of your home charger<sup>2</sup>

To find out whether you are entitled please contact your local Mercedes-Benz Agent.

### Questions?

Please contact your local Mercedes-Benz Agent to submit an enquiry to your chosen charging partner on your behalf. To find your local Mercedes-Benz Agent, please click the button at the top right hand corner.

### Warning!

If you are planning to charge your Mercedes-Benz plug-in electric vehicle using a 3-pin domestic plug socket you must get a qualified electrician to inspect and sign off the socket to confirm it is safe and suitable to charge your vehicle. Do not use an electric vehicle 3-pin charge cable with an extension cord.



\*Price excludes £350 OZEV EVHS Grant. Price correct at time of publication, subject to change <sup>1</sup>Based on an off-peak tariff of 8 p/kWh compared with the energy price cap as of 1 October 2023 of 26.92 p/kWh <sup>2</sup>The home charger £350 Grant (including VAT) is only available to customers who meet the criteria of the Office for Zero Emission Vehicles (OZEV). For full details and eligibility criteria for the OZEV EVHS Grant, see <https://www.gov.uk/government/publications/electric-vehicle-homecharge-scheme-guidance-for-customers-version-21>.



Book a test drive



Find your EQS SUV



Find a Showroom

# EQS SUV Model lines overview

## AMG Line Premium Plus »



## Business Class »



Design	Technology	Safety	Mercedes-EQ	Model lines	Upholstery	Model prices	Personalisation	Standard equipment	Genuine accessories	Technical data	Additional information
--------	------------	--------	-------------	-------------	------------	--------------	-----------------	--------------------	---------------------	----------------	------------------------

# EQS AMG Line Premium Plus SUV



## The ultimate modern choice.

The EQS AMG Line Premium Plus SUV offers plenty of space, comfort and connectivity for up to seven passengers. The exterior is defined through 21" AMG multi-spoke alloy wheels, AMG exterior styling as well as the distinctive radiator grille with Mercedes-Benz star pattern. The interior is accented through the AMG Interior Design package, including

comfort seats and a heated AMG sports steering wheel, as well as nappa leather upholstery in black/space grey complemented by anthracite linestructure lime wood trim.

## EQS AMG Line Premium Plus SUV

**OTR from £129,470<sup>1</sup>**

<sup>1</sup>The recommended on-the-road price includes the Road Fund Licence applicable to the standard model plus delivery charge (£780.00 incl. VAT), new vehicle registration fee (£55.00) and number plates (£25.00 incl. VAT). VAT is calculated at the standard rate of 20%. Some of the model features, optional extras and colours shown may not be available, or may only be available in a different specification, or at a different price

Design	Technology	Safety	Mercedes-EQ	Model lines	Upholstery	Model prices	Personalisation	Standard equipment	Genuine accessories	Technical data	Additional information
--------	------------	--------	-------------	-------------	------------	--------------	-----------------	--------------------	---------------------	----------------	------------------------

# EQS AMG Line Premium Plus SUV

Standard equipment highlights



## Exterior

21" AMG alloy wheels – aerodynamically optimised, painted high-gloss black with a high-shine finish multi-spoke design (code RWX)

Acoustic Comfort package

Aluminium-look, illuminated running boards with rubber studs

AMG exterior styling

Mirror package

Panoramic sliding sunroof

Privacy glass

Radiator grille with Mercedes-Benz star pattern

Summer tyres





### Safety and Assistance Systems

Driving Assistance package Plus<sup>1</sup>

DYNAMIC SELECT

GUARD 360° vehicle protection Plus<sup>2</sup>

KEYLESS-GO Comfort package

<sup>1</sup>Our driver assistance and safety systems are aids and do not relieve you of your responsibility as the driver. Please take note of the information in the Owner's Manual and the system limits which are described therein

<sup>2</sup>The connection of the communication module to the mobile phone network including the emergency call system depends on the respective network coverage and availability of network providers

<sup>3</sup>Compatible mobile phone required

### Communications and In-Car Entertainment

12.3-inch driver instrument cluster display

12.8-inch media display (EQS 450 4MATIC SUV only)

Burmester® 3D surround sound system

EQ navigation services<sup>2</sup>

Fingerprint scanner

Hyperscreen package (EQS 580 4MATIC SUV only)

MBUX Interior Assistant (front)

Wireless charging<sup>3</sup> for mobile devices (front)



### Interior

Active Ambient Lighting

ENERGIZING package

Memory package

AIR-BALANCE package

Heated front, rear and third row seats

Seven seats

AMG Interior Design package

Heated steering wheel

THERMOTRONIC automatic climate control

Climatised front seats

Interior Light package

(front and rear)

### Trim and Upholstery

Nappa leather - black/space grey

Anthracite linestructure lime wood



# EQS Business Class SUV



## Luxury inside out.

The EQS Business Class SUV provides additional comfort features and high entertainment inside the cabin. The spacious interior comes with multi-contour seats including energizing massage function, luxury front head restraints and the stunning Hyperscreen stretches the entire length of the dashboard. In the rear, passengers can

access content via two high-resolution displays thanks to the MBUX high-end rear seat entertainment system.

## EQS Business Class SUV

**OTR from £143,795<sup>1</sup>**

<sup>1</sup>The recommended on-the-road price includes the Road Fund Licence applicable to the standard model plus delivery charge (£780.00 incl. VAT), new vehicle registration fee (£55.00) and number plates (£25.00 incl. VAT). VAT is calculated at the standard rate of 20%. Some of the model features, optional extras and colours shown may not be available, or may only be available in a different specification, or at a different price

Design	Technology	Safety	Mercedes-EQ	Model lines	Upholstery	Model prices	Personalisation	Standard equipment	Genuine accessories	Technical data	Additional information
--------	------------	--------	-------------	-------------	------------	--------------	-----------------	--------------------	---------------------	----------------	------------------------

# EQS Business Class SUV

Standard equipment highlights





**Safety and Assistance Systems**

Augmented head-up display

**Communications and In-Car Entertainment**

Hyperscreen package

MBUX high-end rear seat entertainment system

MBUX Interior Assistant (front and rear)

MBUX rear tablet

Multifunction telephony

TV receiver

Wireless charging<sup>1</sup> for mobile devices (front and rear)

<sup>1</sup>Compatible mobile phone required



In addition to/replacement of AMG Line Premium Plus:

**Interior**

Electric Art interior styling

ENERGIZING package Plus

Luxury front head restraints

Multi-contour seats with energizing massage function

Rear Seat Comfort package

Seat heating Plus for driver and front passenger seats

**Trim and Upholstery**

Nappa leather - macchiato beige/space grey

Ship's deck open-pore Norway maple wood trim

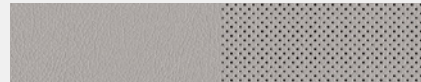





Book a test drive



Find your EQS SUV



Find a Showroom

# Upholstery

● Standard    – Not available



**801A Nappa leather<sup>1</sup> – black/space grey**

AMG Line Premium Plus

●

Business Class

–



**805A Nappa leather<sup>1</sup> – macchiato beige/space grey**

AMG Line Premium Plus

–

Business Class

●

<sup>1</sup>100% of seat upholstery is pure leather    Please note that, owing to limitations of on-screen representation, upholstery colours may differ from those shown

Design	Technology	Safety	Mercedes-EQ	Model lines	Upholstery	Model prices	Personalisation	Standard equipment	Genuine accessories	Technical data	Additional information
--------	------------	--------	-------------	-------------	------------	--------------	-----------------	--------------------	---------------------	----------------	------------------------

[Book a test drive](#)[Find your EQS SUV](#)[Find a Showroom](#)

# Model prices

Model line	Powertrain	CO <sub>2</sub> WLTP <sup>1</sup> *	Basic RRP excl. VAT (£)	Total RRP incl. VAT (£)	Road Fund Licence (£) <sup>2</sup> WLTP	Rec. OTR price (£) <sup>3</sup> WLTP	P11D value (£)	BiK tax rate 2023/24 (%) <sup>2</sup>
<b>AMG Line Premium Plus</b>								
EQS 450 4MATIC SUV	Battery electric vehicle, 360 hp/265 kW Electric range up to 364 miles - WLTP <sup>1</sup>	0	107,175.00	128,610.00	0.00	<b>129,470.00</b>	129,415.00	2
EQS 580 4MATIC SUV	Battery electric vehicle, 544 hp/400 kW Electric range up to 363 miles - WLTP <sup>1</sup>	0	115,508.33	138,610.00	0.00	<b>139,470.00</b>	139,415.00	2
<b>Business Class</b>								
EQS 450 4MATIC SUV	Battery electric vehicle, 360 hp/265 kW Electric range up to 362 miles - WLTP <sup>1</sup>	0	119,112.50	142,935.00	0.00	<b>143,795.00</b>	143,740.00	2
EQS 580 4MATIC SUV	Battery electric vehicle, 544 hp/400 kW Electric range up to 362 miles - WLTP <sup>1</sup>	0	127,445.83	152,935.00	0.00	<b>153,795.00</b>	153,740.00	2

<sup>1</sup>The indicated values were determined according to the prescribed measurement method - Worldwide Harmonised Light Vehicle Test Procedure (WLTP). Figures shown may include options which are not available in the UK. Battery Electric Vehicles (BEV) require mains electricity for charging, range figures determined with the battery fully charged. <sup>2</sup>Figures shown are for comparability purposes; only compare with other cars tested to the same technical procedures. Figures may not reflect real life driving results, which will depend upon a number of factors including the starting charge of the battery, factory-fitted options, accessories fitted (post registration), variations in weather, driving styles and vehicle load. Further information about the test used to establish range, power consumption and CO<sub>2</sub> figures can be found at <http://www.mercedes-benz.co.uk/WLTP> <sup>3</sup>A different first year rate of Vehicle Excise Duty (Road Fund Licence) applies for new cars. Please refer to page 37 for the relevant rate for the second and subsequent years <sup>4</sup>The recommended on-the-road price includes the Road Fund Licence applicable to the standard model plus delivery charge (£780.00 incl. VAT), new vehicle registration fee (£55.00) and number plates (£25.00 incl. VAT). VAT is calculated at the standard rate of 20%. Some of the model features, optional extras and colours shown may not be available, or may only be available in a different specification, or at a different price



Book a test drive



Find your EQS SUV



Find a Showroom

# Colour options

Standard  No-cost option

Total prices incl. VAT



197 obsidian black metallic



989 emerald green metallic



799 MANUFAKTUR diamond white bright

£695.00



842 sodalite blue metallic



992 selenite grey metallic



956 MANUFAKTUR alpine grey solid

£695.00



922 high-tech silver metallic



Please note that, owing to limitations of on-screen representation, paint colours may differ from those shown

Design	Technology	Safety	Mercedes-EQ	Model lines	Upholstery	Model prices	Personalisation	Standard equipment	Genuine accessories	Technical data	Additional information
--------	------------	--------	-------------	-------------	------------	--------------	-----------------	--------------------	---------------------	----------------	------------------------

[Book a test drive](#)[Find your EQS SUV](#)[Find a Showroom](#)

# Hyperscreen package

Enhance your interior with an impressive design feature. As if cast from a single mould, 3 displays seamlessly blend together beneath a glass panel to create one large MBUX hyperscreen. Brilliant OLED technology enhances your display comfort, while the haptic feedback helps to simplify input on the touchscreen.

**Hyperscreen package** (code PAG) – designed and priced as a package.

**EQS 450 4MATIC AMG Line Premium Plus SUV only**

**Total incl. VAT £7,995.00**

Standard on all other model lines and engines



### Consisting of:

17.7-inch central display and a 12.3-inch passenger display

Augmented navigation head-up display – this head-up display projects visual information into your field of vision without distracting you. For example, large direction arrows float above a junction where you need to make a turn. You immediately know what needs to be done

Fingerprint scanner

OLED high-end screens are right next to each other, with minimal space in between to give the impression that this is one large screen

[Design](#)[Technology](#)[Safety](#)[Mercedes-EQ](#)[Model lines](#)[Upholstery](#)[Model prices](#)[Personalisation](#)[Standard equipment](#)[Genuine accessories](#)[Technical data](#)[Additional information](#)

[Book a test drive](#)[Find your EQS SUV](#)[Find a Showroom](#)

# Standard equipment

● Standard    – Not available

## Battery and Charging

	AMG Line Premium Plus	Business Class
22kW on-board charger	●	●
108.4 kWh battery	●	●
200kW on-board charger	●	●
CCS-2 connector (DC charging with combined charging system, compatible with AC and DC)	●	●
Charging cable – Mode 3 cable (5 metres), Type 2, enables you to charge the vehicle battery via the wallbox or at public charging stations	●	●
IONITY unlimited – free rapid charging for one year at all IONITY stations <sup>1</sup>	●	●
Mercedes me Charge <sup>2</sup> – fully integrated access to a host of public charging stations. A single contract covers all billing. One-time registration and activation as part of Mercedes me connect <sup>2</sup> . Use via app, MBUX multimedia system or RFID card	●	●
Vehicle socket flap, electric	●	●

## Steering, Transmission and Suspension

AIRMATIC air suspension struts with integrated adaptive damping system at the front and rear axle – automatic level control system, depending on load: load detection for a constant suspension level. Suspension level can be raised for rough roads and is automatically lowered at high speeds, MBUX can remember these actions and suggest them when arriving at the same location. At the touch of a button, you can also extend the ground clearance by up to 25 mm	●	●
DYNAMIC SELECT – four different drive programs: ECO, COMFORT, SPORT and OFF-ROAD drive programs with the ability to save an INDIVIDUAL program, five recuperation levels: D Auto (ECO Assist, standard setting), D + (coasting), D (low recuperation), D - (medium recuperation), D - - (high recuperation)	●	●
Steering – 10° rear axle steering	●	●

## Exterior

	AMG Line Premium Plus	Business Class
Acoustic Comfort package – for an extraordinarily calm vehicle interior: special glass membranes, reinforced felts and additional insulation effectively help to reduce disruptive exterior noise	●	●
Aluminium-look, illuminated running boards with rubber studs	●	●
AMG exterior styling	●	●
Headlamps – DIGITAL LIGHT	●	●
Heat-insulating, noise-insulating and infrared-reflecting laminated glass	●	●
Heated windscreen washer system	●	●
Mirror package – electrically folding exterior mirrors, automatically dimming interior and exterior driver mirror, surround lighting in both outside mirrors with brand logo projection to illuminate the entrance area	●	●
Panoramic sliding sunroof	●	●
Privacy glass – dark tinted rear and rear side windows	●	●
Radiator grille with Mercedes-Benz star pattern	●	●

## Wheels

21" AMG alloy wheels – multi-spoke design, aerodynamically optimised, painted black with a high-sheen finish, 265/40 R21 tyres (code RWX)	●	●
Summer tyres	●	●

<sup>1</sup>With the Mercedes me connect IONITY unlimited service, charging costs are only included for EQS customers for one year from activation of the service. Please note that this exclusive offer is applicable to the first registered owner of the vehicle only and expires at the end of a period of one year from the activation of the service and cannot be transferred to third parties

<sup>2</sup>The connection of the communication module to the mobile phone network including the emergency call system depends on the respective network coverage and availability of network providers

[Book a test drive](#)[Find your EQS SUV](#)[Find a Showroom](#)

# Standard equipment

● Standard    – Not available

## Interior

	AMG Line Premium Plus	Business Class
AIR-BALANCE package	●	●
AMG Interior Design package – comfort seats, AMG sports steering wheel, AMG pedals, AMG door sills with AMG illuminated lettering and AMG velour floor mats	●	–
Electric Art Interior Design package – comfort seats, multifunction steering wheel in nappa leather and black velour floor mats	–	●
ENERGIZING package	●	–
ENERGIZING package Plus	–	●
Lighting – active ambient lighting – 64 colours with direct light lines	●	●
Lighting – Interior Light package	●	●
Memory package – electrical adjustment and memory function for front seats, steering wheel, outside mirror, heated areas of the seat cushion and seat backrest, head-up display (where fitted), four-way front lumbar support and seat cushion length. Includes PRE-SAFE® positioning function for front passenger seat	●	●
Partition net	●	●
Pullout sunvisor	–	●
Seats – climatized (front)	●	●
Seats – heated (front, rear and third row)	●	●
Seats – luxury front head restraints	–	●
Seats – multi-contour seats with energizing massage function	–	●

	AMG Line Premium Plus	Business Class
Seats – Seat Comfort package (rear)	–	●
Seats – Seat heating Plus (front)	–	●
Seats – seven seats	●	●
Seats – split-folding rear seats	●	●
Soft closing doors	●	●
Steering wheel – heated	●	●
Storage compartment under centre console	●	●
THERMOTRONIC automatic climate control (front and rear)	●	●

## Paint, Trim and Upholstery

Dashboard in leather look	●	●
Paint – metallic	●	●
Roof lining – black fabric	●	–
Roof lining – macchiato beige fabric	–	●
Trim – lower trim (when Hyperscreen package not selected) – black fine structure	●	–
Trim – main trim – anthracite linestructure lime wood	●	–
Trim – main trim – ship's deck open-pore Norway maple wood	–	●
Upholstery – nappa leather	●	●

[Book a test drive](#)[Find your EQS SUV](#)[Find a Showroom](#)

# Standard equipment

● Standard    – Not available

## Safety and Assistance Systems

	AMG Line Premium Plus	Business Class
Driving Assistance package Plus <sup>1</sup> (please refer to page 11 for full details)	●	●
EASY-PACK tailgate	●	●
GUARD 360° vehicle protection Plus <sup>2</sup> – with anti-theft protection hardware including alarm and immobilizer. Theft notification and park damage detection <sup>3</sup> , stolen vehicle locator <sup>3</sup> , 360° surroundview-camera snapshots <sup>3</sup> and remote key immobilizer <sup>3</sup>	●	●
KEYLESS-GO Comfort package	●	●
Mercedes-Benz emergency call system <sup>2</sup>	●	●
Parking package with Active Parking Assist <sup>1</sup> and 360° camera	●	●
Tirefit	●	●

## Communications and In-Car Entertainment

	AMG Line Premium Plus	Business Class
5G communications module <sup>2</sup>	●	●
12.3-inch digital instrument cluster display	●	●
12.8-inch media display (EQS 450 4MATIC SUV only)	●	–
Digital radio	●	●
EQ navigation services <sup>2</sup> – navigation optimised for Mercedes-EQ, range on map (range display), display of charging stations (info on availability, programming of charging settings and Pre-Entry Climate Control <sup>2</sup> incl. remote retrieval of charging status and range	●	●
Fingerprint scanner – colour-illuminated fingerprint scanner in the trim strip below the OLED media display, two fingerprints per user can be stored, quick access replaces PIN entry, protects personal data such as profiles plus office and payment functions	●	●

	AMG Line Premium Plus	Business Class
Hard-disc navigation	●	●
Head-up display (EQS 450 4MATIC SUV only)	●	–
Head-up display – Augmented head-up display (optional on EQS 450 4MATIC AMG Line Premium Plus SUV)	●	●
Hyperscreen package (optional on EQS 450 4MATIC AMG Line Premium Plus SUV)	●	●
Live traffic information <sup>2</sup> – 3 years	●	●
MBUX high-end rear seat entertainment system	–	●
MBUX Interior Assistant (front)	●	●
MBUX Interior Assistant (rear)	–	●
MBUX rear tablet	–	●
Pre-entry climate control <sup>2</sup>	●	●
Pre-installation for Car Sharing <sup>2</sup>	●	●
Smartphone integration <sup>4</sup>	●	●
Sound personalisation	●	●
Sound system – Burmester® 3D surround sound system	●	●
TV receiver	–	●
USB package – six fast charging USB-C ports including four compatible for data transfer	●	●
Wireless charging <sup>4</sup> for mobile devices (front)	●	●
Wireless charging <sup>4</sup> for mobile devices (rear)	–	●

<sup>1</sup>Our driver assistance and safety systems are aids and do not relieve you of your responsibility as the driver. Please take note of the information in the Owner's Manual and the system limits which are described therein of network providers

<sup>2</sup>Free of charge for three years from activation

<sup>3</sup>Compatible smartphone required. For further details please visit <https://www.mercedes-benz-mobile.com/>

<sup>4</sup>The connection of the communication module to the mobile phone network including the emergency call system depends on the respective network coverage and availability



# Standard equipment

● Standard    – Not available

## Services

Geofencing<sup>1</sup> – available to use free of charge for three years following activation<sup>2</sup>, denotes a specific area and notifies via push message when the vehicle leaves or enters this area

Mercedes me services

Parked vehicle locator<sup>1</sup> – available to use free of charge for three years following activation<sup>2</sup>, shows the position of the parked vehicle in a radius of approx. 1.5 km

Personalisation<sup>1</sup> – available to use free of charge for three years following activation<sup>2</sup>, stores settings such as the radio station or navigation destination in the personal driver profile and enables these to be used in vehicles with the same telematics generation, the profile can be linked to the key, and the functions can therefore already be activated before getting in

Programming of auxiliary heater/ventilation<sup>1</sup>

Remote door locking and unlocking<sup>1</sup> – available to use free of charge for three years following activation<sup>2</sup>, provides convenient remote monitoring

Remote retrieval of vehicle status<sup>1,2</sup> – shows mileage, tyre pressure, washer fluid level, etc.

Remote vehicle finder<sup>1</sup> – available to use free of charge for three years following activation<sup>2</sup> indicators activated via the app help to draw attention to the vehicle, for example in large, confusing car parks

Sliding sunroof/windows with remote closing and opening including ventilation function<sup>1</sup> to use free of charge for three years following activation<sup>2</sup> for a breath of fresh air in the vehicle available

Send2Car function<sup>1</sup> – available to use free of charge for three years following activation<sup>2</sup>, sends selected addresses via the app to the vehicle's navigation system, for example POIs or restaurants

AMG Line Premium Plus  
Business Class

- ●
- ●
- ●
- ●
- ●
- ●
- ●
- ●
- ●
- ●

Speed fencing<sup>1</sup>

Stolen Vehicle Help<sup>1</sup> (free of charge for 3 years from activation) – this service reduces the bureaucratic effort required and gives you an advantage in terms of time. In the event of theft, you can report it to the police. You can transfer the police file number (depending on country) plus the relevant vehicle and owner information quite simply via app to our certified partner's security centre. This centre will then coordinate with the local police station to track your vehicle

Valet protect<sup>1</sup> – available to use free of charge for 3 years following activation<sup>2</sup> notifies via the app when the ignition is switched on/off and when the vehicle moves outside a defined radius (1km, 2.5 km or 5 km)

Vehicle Tracking<sup>1</sup>

- ●
- ●
- ●
- ●
- ●

AMG Line Premium Plus  
Business Class

<sup>1</sup>The connection of the communication module to the mobile phone network including the emergency call system depends on the respective network coverage and availability of network providers

<sup>2</sup>To use this service, you must register on the Mercedes me portal and also accept the Terms of Use for the Mercedes me connect services. In addition, the respective vehicle must be paired with the user account. Upon expiry of the initial term, the services can be extended for a fee. Initial activation of the services is possible within 1 year of first registration or commissioning by the customer, whichever occurs first



# Genuine accessories

We've developed a range of accessories you can add to help personalise and enhance your EQS SUV.



## Velour floor mats, classic

Our Mercedes-Benz floor mats have to undergo rigorous testing before they are deemed worthy of the star logo. Long durability, fade-resistant colour and a neutral odour, even after three winters of use, are all specifications which must be met without compromise. The mats are precision-tailored to your Mercedes-Benz. They are clip-fastened to the floor of the vehicle to prevent slipping.

(Five piece set: A29668001069J74)

(Three piece set: A29668099059J74)



## Reversible boot mat

Better safe than sorry: the double sided, non-slip mat from Mercedes-Benz helps keep the floor of the boot/load compartment clean and dry. 100% hardwearing polyester. And if anything does get spilt the reversible mat is easy to clean using warm water.

(Five-seater: A2966805405)

(Seven-seater: A2966809705)



## DUO plus child seat, with ISOFIX

Safe and secure: children between the ages of 9 months and 4 years (weight 9 to 18 kg) will enjoy travelling in the DUO plus child seat from Mercedes-Benz. The seat offers optimum protection in the event of an accident. A quick change of position: sitting, reclining and sleeping positions are adjustable with one simple manoeuvre.

(A0009704302)



## Boot tub

Made from impact-resistant, non-slip polypropylene. Structured surface holds separately available stowage crate in place. Vehicle's load-securing rings remain accessible.

(A2968140700)

All the above accessories are subject to availability and compatibility. Please ask your Mercedes-Benz Authorised Repairer for more information. Images shown are for illustration purposes only.

Design	Technology	Safety	Mercedes-EQ	Model lines	Upholstery	Model prices	Personalisation	Standard equipment	Genuine accessories	Technical data	Additional information
--------	------------	--------	-------------	-------------	------------	--------------	-----------------	--------------------	---------------------	----------------	------------------------

[Book a test drive](#)[Find your EQS SUV](#)[Find a Showroom](#)

# Technical data

- Standard

Model	EQS 450 4MATIC SUV	EQS 580 4MATIC SUV
<b>Motor</b>		
Battery type	lithium-ion high-voltage	lithium-ion high-voltage
Electric motor type	asynchronous	asynchronous
Battery capacity	kWh 108.4	108.4
Power <sup>1</sup>	hp (kW) 360 (265)	544 (400)
Torque <sup>1</sup>	Nm at rpm 800/3,183	858/4,822
On-board charger	kW 22AC; 200 DC	22AC; 200 DC
Emissions standard	EU6	EU6

Transmission	EQS 450 4MATIC SUV	EQS 580 4MATIC SUV
Single-speed automatic	●	●

Performance	EQS 450 4MATIC SUV	EQS 580 4MATIC SUV
Acceleration 0–62 mph	sec 6.0	4.6
Top speed	mph 130	130
Charging time		
Public Rapid charger (200 kW DC) 10–80% <sup>2</sup>	31 mins	31 mins
Wallbox (22 kW AC) 10–100% <sup>3</sup>	5 hrs 30 mins	5 hrs 30 mins
Home wallbox (7.4 kW AC) 10–100% <sup>3</sup>	16 hrs 45 mins	16 hrs 45 mins
Range power consumption combined <sup>4,5</sup>	Wh/km 212–211	212–211
Electric range – WLTP <sup>4</sup>	miles 362–364	362–363

Model	EQS 450 4MATIC SUV	EQS 580 4MATIC SUV
<b>Weights and capacities</b>		
Kerb weight <sup>6</sup>	kg 2,805	2,810
Perm. Gross Vehicle Weight	kg 3,375	3,375
Boot capacity – seats up/down	l 565/2,020	565/2,020
Turning circle	m 11.0	11.0

Insurance	EQS 450 4MATIC SUV	EQS 580 4MATIC SUV
All variants	50E	50E

Insurance ratings may vary depending on model line and specification.

Please refer to <http://www.thatcham.org/abigroupating/> for further details

<sup>1</sup>Figures according to Regulation (EC) No. 595/2009 in the currently applicable version <sup>2</sup>Specified voltage and current values refer to network infrastructure and can be limited by the vehicle. Times are from 10–80% charge using public rapid charging at 200 kW <sup>3</sup>Specified voltage and current values refer to network infrastructure and can be limited by the vehicle. Times are from 10–100% charge using a wallbox (three-phase) or standard socket (single-phase) <sup>4</sup>Figures shown are for comparability purposes; only compare with other cars tested to the same technical procedures. Figures may not reflect real life driving results, which will depend upon a number of factors including the starting charge of the battery, factory-fitted options, accessories fitted (post registration), variations in weather, driving styles and vehicle load. Further information about the test used to establish range, power consumption and CO<sub>2</sub> figures can be found at <http://www.mercedes-benz.co.uk/WLTP> <sup>5</sup>Specified voltage and current values refer to network infrastructure and can be limited by the vehicle <sup>6</sup>Mass of the vehicle in running order with at least 90% full fuel tank, plus the mass of the driver (estimated by law at 75 kg), fuel and fluids, equipped with the standard equipment as specified by the manufacturer as well as, where applicable, the mass of the body, cab, trailer coupling and spare wheel(s) as well as tools. Optional extras, additional equipment and accessories can influence the weight, residual payload, rolling resistance, aerodynamics, etc., and therefore also affect the consumption/CO<sub>2</sub> values

[Book a test drive](#)[Find your EQS SUV](#)[Find a Showroom](#)

# Electric range and consumption

Model	Energy Consumption – combined (Wh/km) <sup>1,2</sup>	All Electric Range (km) <sup>2</sup>	All Electric Range (miles) <sup>2</sup>
EQS 450 4MATIC AMG Line Premium Plus SUV	211	587	364
EQS 450 4MATIC AMG Line Premium Plus SUV + Hyperscreen	211	585	363
EQS 450 4MATIC Business Class SUV	212	583	362
EQS 580 4MATIC AMG Line Premium Plus SUV	211	585	363
EQS 580 4MATIC Business Class SUV	212	583	362

<sup>1</sup>Specified voltage and current values refer to network infrastructure and can be limited by the vehicle <sup>2</sup>Figures shown are for comparability purposes; only compare with other cars tested to the same technical procedures. Figures may not reflect real life driving results, which will depend upon a number of factors including the starting charge of the battery, factory-fitted options, accessories fitted (post registration), variations in weather, driving styles and vehicle load. Further information about the test used to establish range, power consumption and CO<sub>2</sub> figures can be found at <http://www.mercedes-benz.co.uk/WLTP>



Book a test drive



Find your EQS SUV



Find a Showroom

# EQS SUV

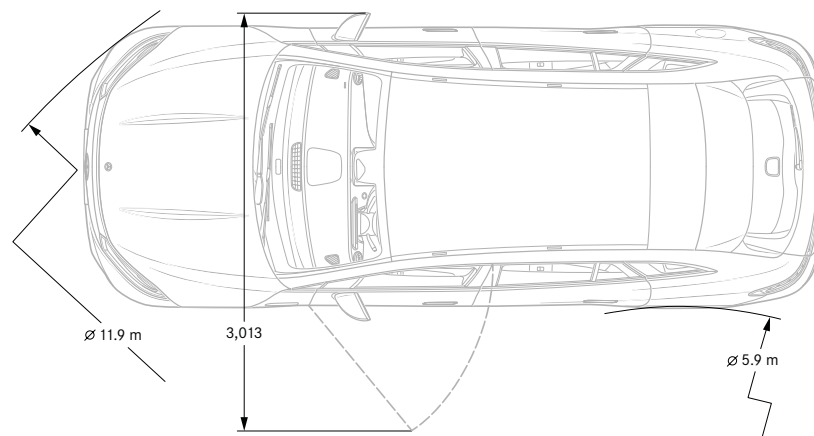
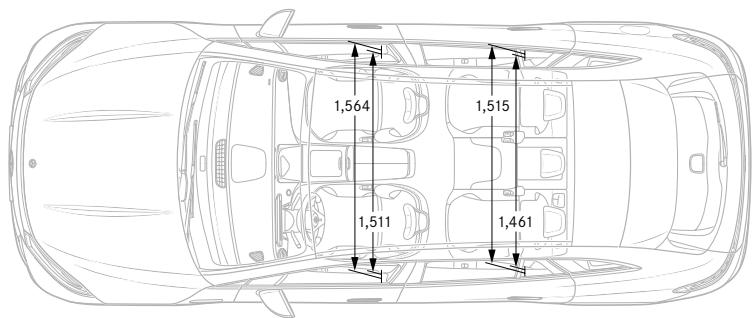
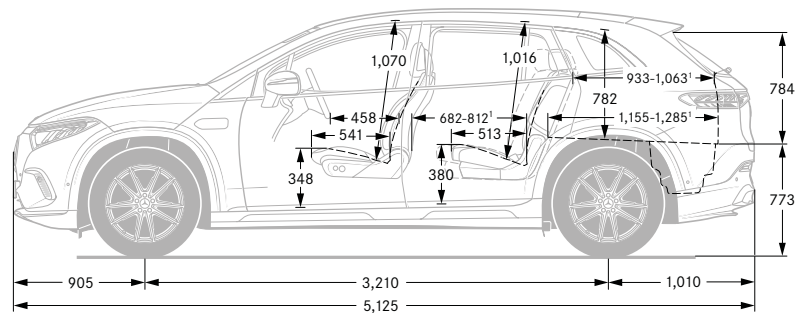
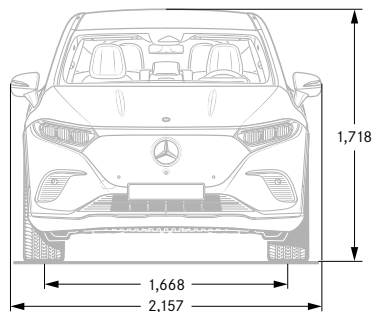

All measurements in millimetres. The dimensions shown are mean values and apply to standard-specification, unladen vehicles

<sup>1</sup>Movable rear bench seat, vehicle length without number-plate adapter (2 mm)

Design	Technology	Safety	Mercedes-EQ	Model lines	Upholstery	Model prices	Personalisation	Standard equipment	Genuine accessories	Technical data	Additional information
--------	------------	--------	-------------	-------------	------------	--------------	-----------------	--------------------	---------------------	----------------	------------------------



# Road Fund Licence

All road vehicle registrations are subject to Vehicle Excise Duty (Road Fund Licence), which varies in accordance with the vehicle's CO<sub>2</sub> emissions. A first year rate for each taxation band will apply. The table below shows the bands (A–M) created by the DVLA and the corresponding Road Fund Licence. CO<sub>2</sub> emissions and the relevant Excise Duty are shown on the model pricing page.

Band	CO <sub>2</sub> emissions (g/km)	First year rate petrol and RDE2 diesel (£)	First year rate alternative fuel (£)	Electric vehicles		Alternative fuel vehicles		Petrol/diesel vehicles	
				Standard rate (£)	Premium rate (£) <sup>1</sup>	Standard rate (£)	Premium rate (£) <sup>1</sup>	Standard rate (£)	Premium rate (£) <sup>1</sup>
A	0	0.00	0.00	0.00	0.00	0.00	0.00	0.00	0.00
B	1 to 50	10.00	0.00	0.00	0.00	170.00	560.00	180.00	570.00
C	51 to 75	30.00	20.00	0.00	0.00	170.00	560.00	180.00	570.00
D	76 to 90	130.00	120.00	0.00	0.00	170.00	560.00	180.00	570.00
E	91 to 100	165.00	155.00	0.00	0.00	170.00	560.00	180.00	570.00
F	101 to 110	185.00	175.00	0.00	0.00	170.00	560.00	180.00	570.00
G	111 to 130	210.00	200.00	0.00	0.00	170.00	560.00	180.00	570.00
H	131 to 150	255.00	245.00	0.00	0.00	170.00	560.00	180.00	570.00
I	151 to 170	645.00	635.00	0.00	0.00	170.00	560.00	180.00	570.00
J	171 to 190	1,040.00	1,030.00	0.00	0.00	170.00	560.00	180.00	570.00
K	191 to 225	1,565.00	1,555.00	0.00	0.00	170.00	560.00	180.00	570.00
L	226 to 255	2,220.00	2,210.00	0.00	0.00	170.00	560.00	180.00	570.00
M	over 255	2,605.00	2,595.00	0.00	0.00	170.00	560.00	180.00	570.00

Some of the model features, optional extras and colours shown may not be available, or may only be available in a different specification, or at a different price.

<sup>1</sup>Premium rate only applicable to vehicles where the list price is over £40,000 including any factory-fitted options, standard UK delivery charge and VAT

Design	Technology	Safety	Mercedes-EQ	Model lines	Upholstery	Model prices	Personalisation	Standard equipment	Genuine accessories	Technical data	Additional information
--------	------------	--------	-------------	-------------	------------	--------------	-----------------	--------------------	---------------------	----------------	------------------------

# Services and insurance

## Mercedes-Benz ServiceCare

We believe that servicing costs should be as flexible and affordable as possible for your EQS SUV, which is why we offer ServiceCare, an easy way to budget for all your servicing costs. It spreads your bills into manageable payments based on whether you have a new or used Mercedes-Benz.

With ServiceCare we guarantee the price of parts and labour for up to four services and safeguard against any further inflation.

You can choose either to add your servicing costs into your monthly spend or pay the full amount in a one-off payment, giving you peace of mind that they are taken care of for the period of the plan.

[Click here for more information](#)

## Warranty and breakdown cover

Every Mercedes-Benz comes with a three-year unlimited mileage warranty against manufacturing or material defects<sup>1</sup> and up to 30 years warranty against perforation due to corrosion from the inside out.<sup>2</sup> What's more, it's also covered by Mercedes-Benz Roadside Assistance – a unique package comprising up to 30 years pan-European breakdown assistance.<sup>2</sup>

## Battery Warranty

The battery comes with a 10-year 155,000-mile warranty.<sup>3</sup>

## Motor Insurance

We know that once you have chosen your Mercedes-Benz you can't wait to drive it – that's why we created First Cover.<sup>4</sup> It gives you 7 days' free comprehensive Motor Insurance when you buy a new or used vehicle from a Mercedes-Benz Agent. We will also send you a quote for annual cover, so you can enjoy the same peace of mind all year round.

[Apply for First Cover](#)



<sup>1</sup>Applies to vehicles sold by Mercedes-Benz in the UK to its franchised Mercedes-Benz Agents

<sup>2</sup>Subject to full Terms and Conditions, dependent on date of registration, available upon request

<sup>3</sup>Cars that hold a Hackney carriage vehicle licence (Taxicab) and/or Taxi Operator licence issued by a local authority, come with a 3-year 155,000-mile battery warranty

<sup>4</sup>Terms and Conditions apply. We are an independent intermediary dealing with selected insurers in respect of annual insurance



Effective from August 2023 Production. Information correct at time of publication 05.05.2023.  
Prices and specifications are subject to change without prior notice.  
MBX296PL/1123 MY804

